

BQ2L BLOCK DIAGRAM

01

- CPU CORE MAX8771
POWER VCORE PG 32
- SYSTEM MAX8734AEEI+
POWER(3/5V) PG 33
- SYSTEM POWER MAX8743
(VCCP) PG 36
- SYSTEM POWER APL5331
(+1.5V) PG 37
- SYSTEM POWER MAX8632ETI+
(1.8VSUS/0.9V SMDDR_VREF) PG 34
- BATT CHARGER
MAX8724 PG 35
- BATTERY CONNECTOE PG35

- CRT port PG 18 R,G,B
- LCD Panel PG 23 LVDS X1
- S-VIDEO PG 18 TV-OUT

- SATA - HDD PG 26 SATA 150MB
- IDE - ODD PG 26 ATA 66/100/133

- USB PORT 1 PG 30
- USB PORT 3 PG 30
- USB PORT 5 PG 30
- USB PORT 7 PG 30
- USB PORT 0 PG 29
- USB PORT 2 PG 29
- Bluetooth PG 29
- CIR PG 29

CPU Yonah/Merom
479 Pins (uPGA)
PG 4,5

CPU THERMAL SENSOR
GMT781
PG 31

CLOCK GEN
ICS9LPR600
56pins
PG 3

MEM CLK BUF
ICS9P935
PG 3

SiS M662MX
Integrated VGA Function
801 BGA (31X31)
PG 6,7,8,9

SiS 307LV
PG 10

DDRII-SODIMM1
PG 16,17

DDRII-SODIMM2
PG 16,17

SiS 966L
588 BGA (27X27)
PG 12,13,14,15

PHY 10/100
RTL8201CL
PG 22

Magnetics
PG 25

RJ45
PG 25

CARDBUS R5C832
PG 19,20

IEEE 1394
PG 20

4 IN 1
PG 21

PC87541
TQFP 176pins
PG 31

MDC
PG 29

Azalia
AUDIO CODEC
ALC262H
PG27

AMP
MAX9755
PG28

- FAN PG24
- Touch PAD PG29
- Key Board PG30
- FLASH ROM PG31

- RJ11 PG25
- LINE IN PG28
- MIC PG 27
- INT SPK PG28
- HP PG28

QUANTA COMPUTER

Title: **BLOCK DIAGRAM**

Size	Document Number	Rev
Custom	BQ2L MAIN BOARD	1A
Date:	Friday, August 25, 2006	Sheet 1 of 38

Board Stack up Description

PCB Layers

Layer 1		TOP (Component, Other)
Layer 2		Ground Plane
Layer 3		IN1
Layer 4		IN2
Layer 5		Power Plane
Layer 6		IN3
Layer 7		Ground Plane
Layer 8		BOTTOM

Power On Sequencing Timing Diagram

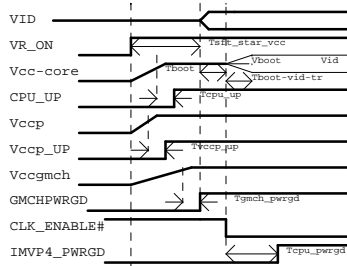

Dothan Power-up Timing Specifications

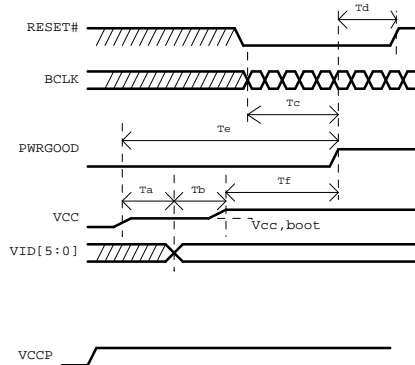

Ta=VCC and VCCP assertion to VID[5:0] valid
 Tb=VID[5:0] stable to VCC valid
 Tc=BCLK stable to PWRGOOD assertion
 Td=PWRGOOD to RESET# de-assertion time
 Te=Vcc.boot valid to PWRGOOD assertion time

Voltage Rails

Voltage Rails	ON S0-S2	ON S3	ON S4	ON S5	Control signal
VCC_CORE Core voltage for Processor	X				VR_ON 0.726V-0.94V
VCCP Core voltage for CPU / NB	X				VR_ON
SMDRR_VTERM0.9V for DDR2 Termination voltage	X				MAINON
RVCC1.5	X	X	X		RVCC_ON
RVCC3	X	X	X		RVCCD
VCC1.5	X				MAIND
VCC2.5	X				MAINON
VCC3	X				MAIND
VCC5	X				MAIND
1.8VSUS	X	X			SUSON
3VSUS	X	X			SUSD
5VSUS	X	X			SUSD
3VPCU	X	X	X	X	VL
5VPCU	X	X	X	X	VL
9VPCU	X	X	X	X	5VPCU

ACIN POWER ON TIMING

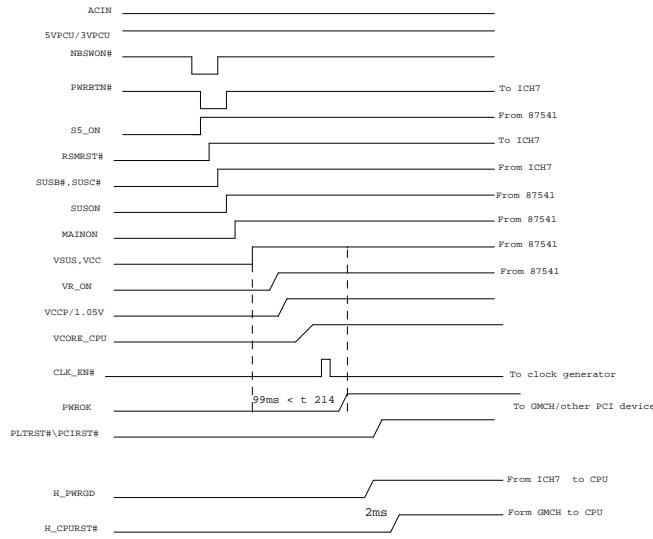

Voltage Rails	ON S0-S1	ON S3	ON S4	ON S5	Control signal
VCC_CORE Core voltage for Processor	X				VRON
GMCH_VTT Core voltage for GMCH 1.05V	X				MAINON
SMDRR_VTERM 0.9V for DDR II Termination voltage	X				MAINON
SMDRR_VREF 0.9V for DDR II Reference Voltage	X				MAINON
GMCH 1.5V	X				MAINON
1.8V/SUS 1.8V for DDR II voltage	X	X			SUSON
2.5V	X				MAINON
3VPCU	X	X	X	X	VL
3VSUS	X	X			SUSON
5V	X				MAINON
5VPCU	X	X	X	X	VL
5VSUS	X	X			SUSON
9V	X				MAINON
9V	POWER SOURCE				
	X	X	X	X	

PCI DEVICE	IDSEL#	REQ# / GNT#	Interrupts
PCI#402	AD20	REQ2# / GNT2#	PIRO CD

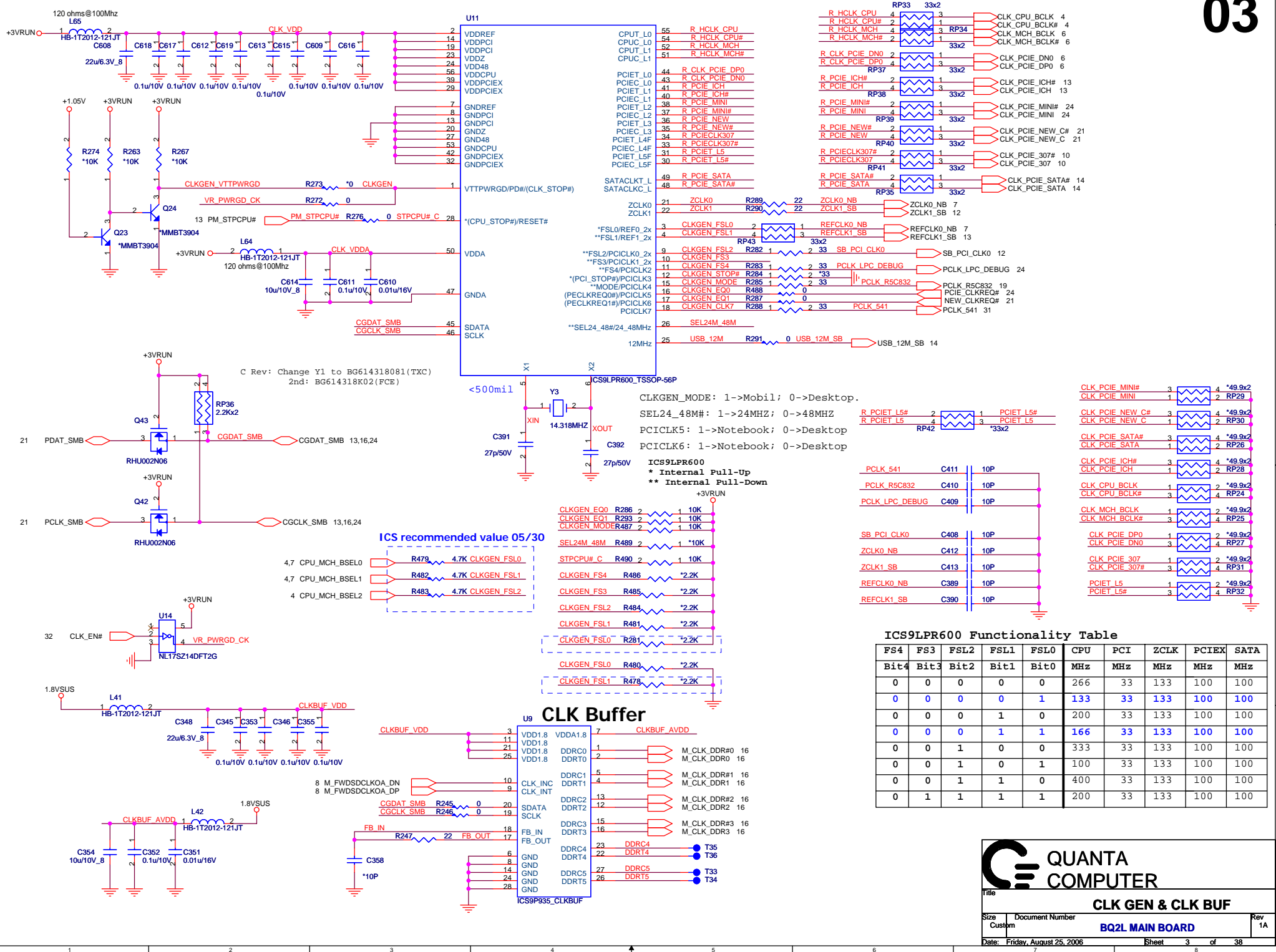

QUANTA COMPUTER

Title: **CLK GEN & CLK BUF**

Size: Custom Document Number: **BQ2L MAIN BOARD** Rev: 1A

Date: Friday, August 25, 2006 Sheet: 3 of 38

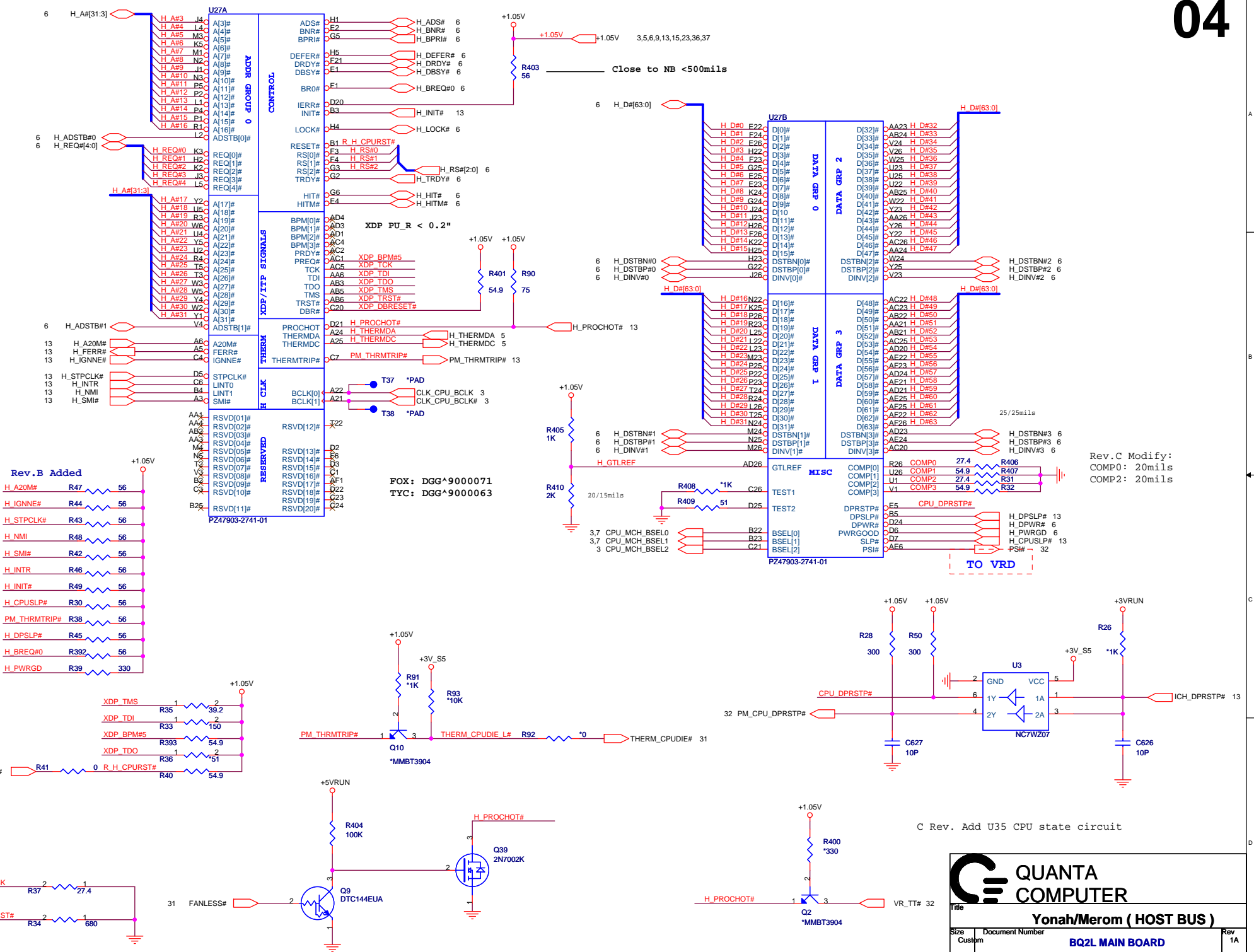

Rev.C Modify:
COMP0: 20mils
COMP2: 20mils

FOX: DGG^9000071
TYC: DGG^9000063

- Rev.B Added**
- H_A20M# R47 56
 - H_IGNNE# R44 56
 - H_STPCLK# R43 56
 - H_NMI# R48 56
 - H_SMI# R42 56
 - H_INTR# R46 56
 - H_INIT# R49 56
 - H_CPUSLP# R30 56
 - PM_THRMTRIP# R38 56
 - H_DPSLP# R45 56
 - H_BREQ# R392 56
 - H_PWRGD R39 330

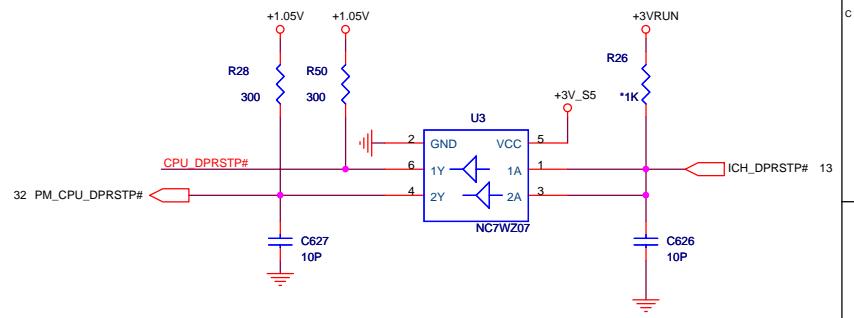
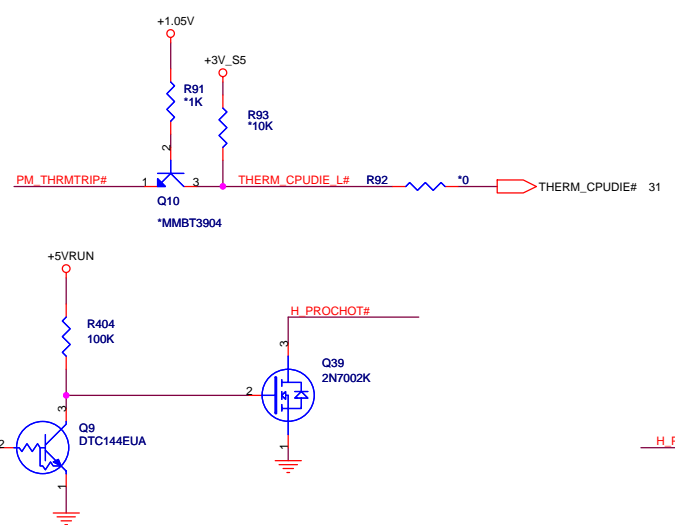
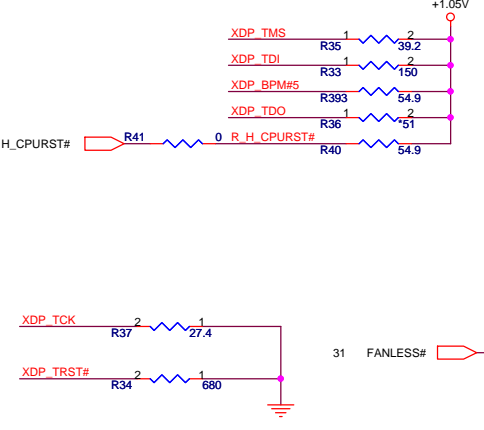

C Rev. Add U35 CPU state circuit

QUANTA COMPUTER

Yonah/Merom (HOST BUS)

Size: Custom Document Number: BQ2L MAIN BOARD Rev: 1A

Date: Friday, August 25, 2006 Sheet: 4 of 38

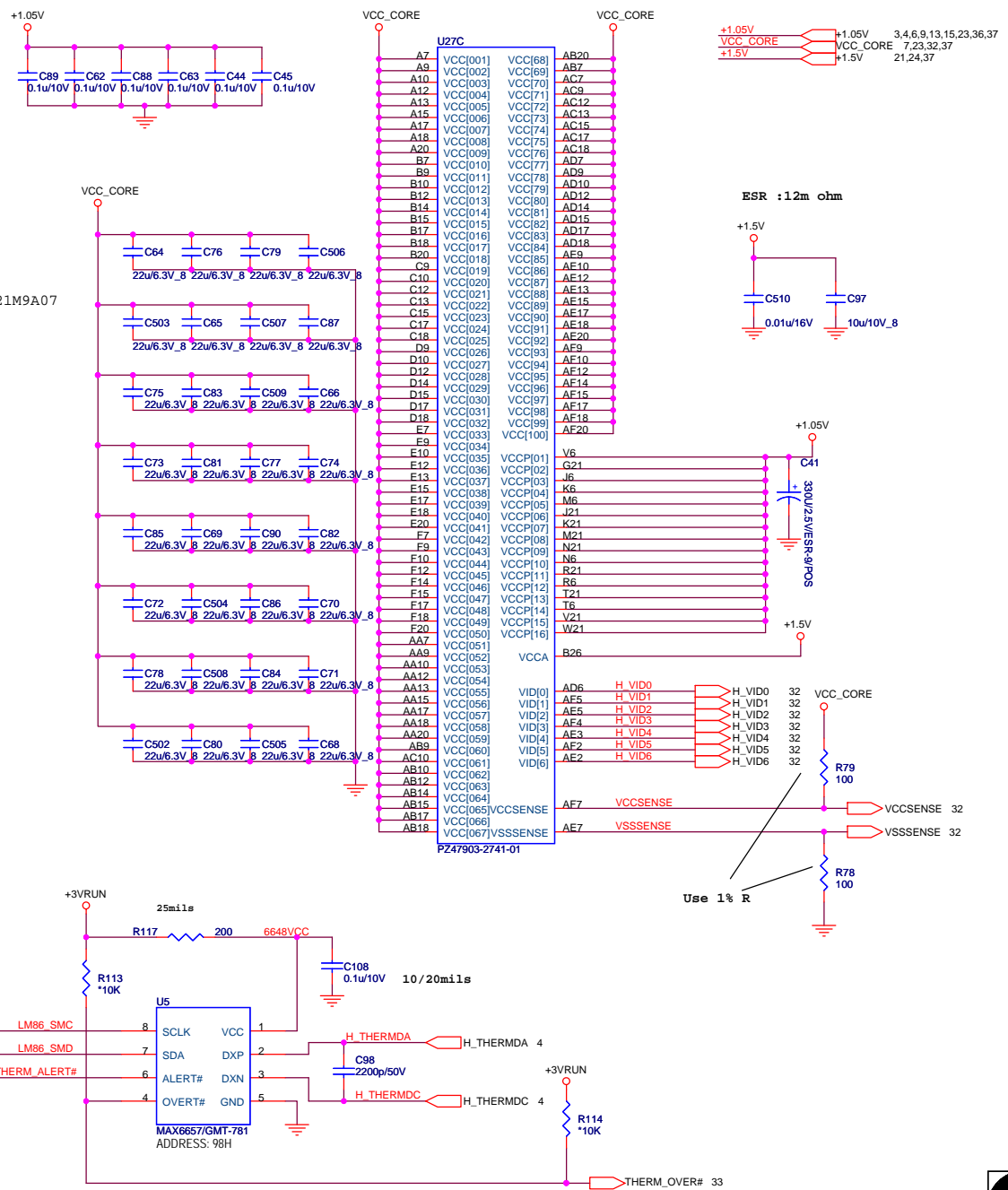

C-Test: Change to CH6221M9A07
22uF/6.3V/X5R/0805

ESR : 1.2m ohm

Use 1% R

QUANTA COMPUTER

Title: **Yonah/Merom (POWER/NC)**

Size: Custom Document Number: **BQ2L MAIN BOARD** Rev: 1A

Date: Friday, August 25, 2006 Sheet: 5 of 38

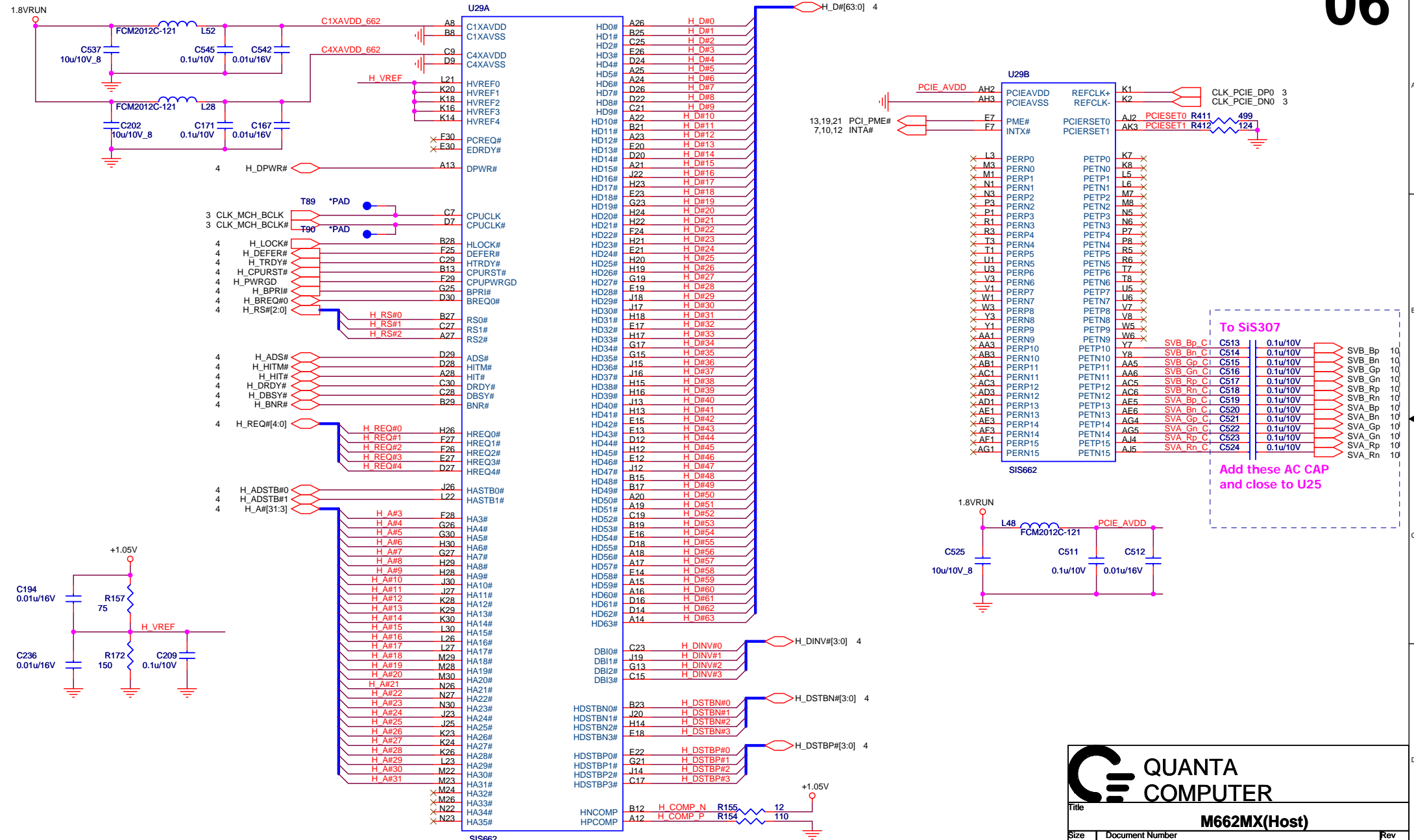

To SIS307

SVB Bp	C513	0.1u/10V
SVB Bn	C514	0.1u/10V
SVB Gp	C515	0.1u/10V
SVB Gn	C516	0.1u/10V
SVA Bp	C517	0.1u/10V
SVA Bn	C518	0.1u/10V
SVA Gp	C519	0.1u/10V
SVA Gn	C520	0.1u/10V
SVA Rp	C521	0.1u/10V
SVA Rn	C522	0.1u/10V
SVA Bp	C523	0.1u/10V
SVA Bn	C524	0.1u/10V

Add these AC CAP and close to U25

QUANTA COMPUTER

Title: **M62MX(Host)**

Size B Document Number: **BQ2L MAIN BOARD** Rev 1A

Date: Friday, August 25, 2006 Sheet 6 of 38

12 ZAD[16:0]

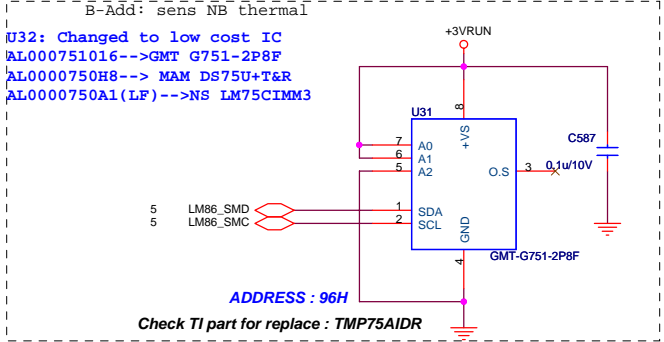
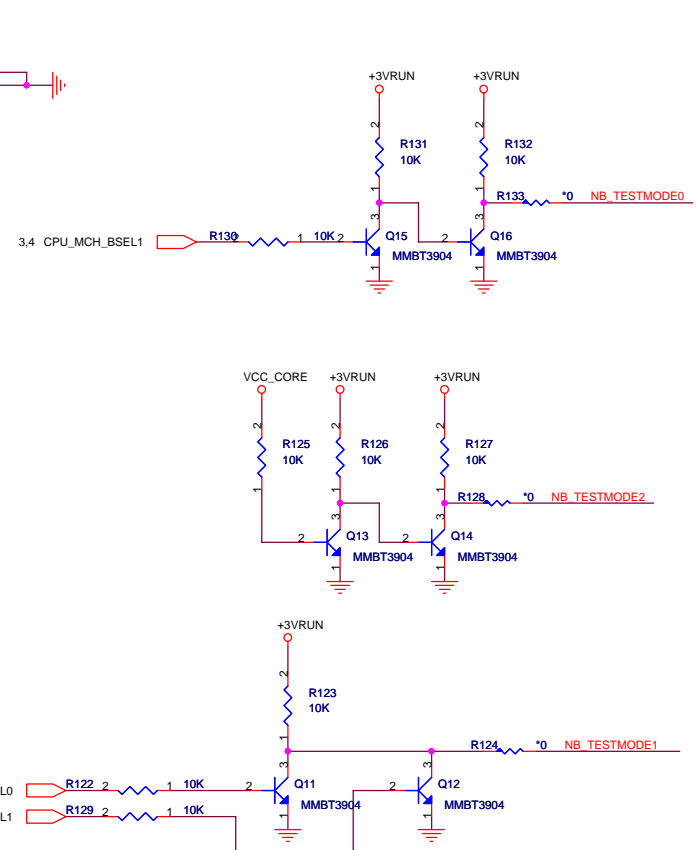
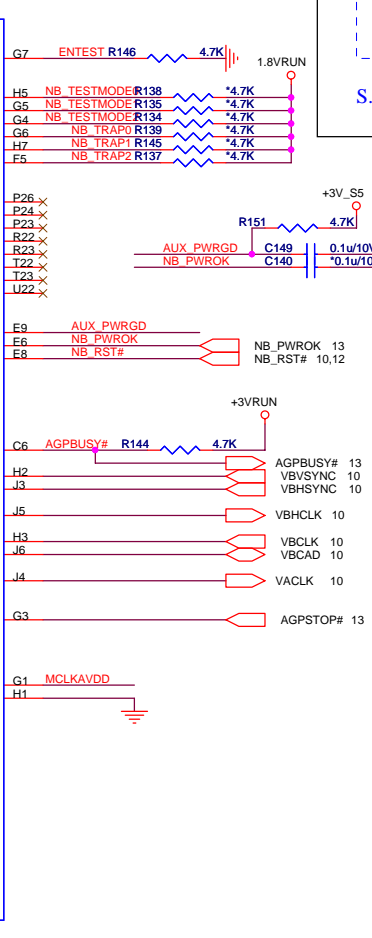
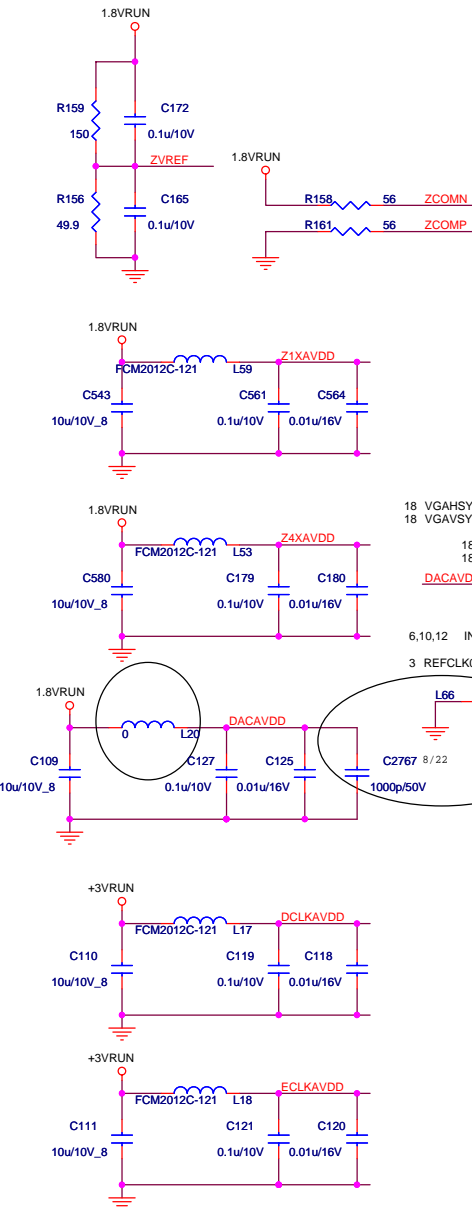
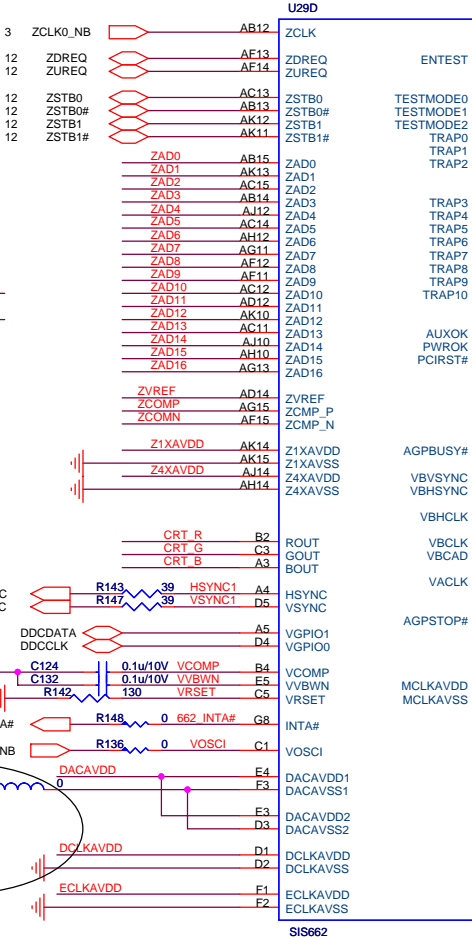
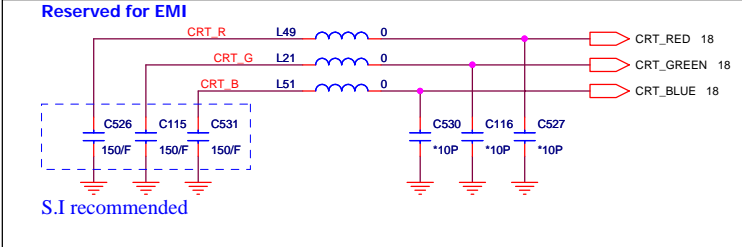

QUANTA COMPUTER

File M662MX(VGA,MuTIOL,Therm.)

Size	Document Number	Rev
Custom	BQ2L MAIN BOARD	1A

Date: Friday, August 25, 2006 Sheet 7 of 38

U29C

M A DQ0	P28	MDA0
M A DQ1	R30	MDA1
M A DQ2	U27	MDA2
M A DQ3	U30	MDA3
M A DQ4	P30	MDA4
M A DQ5	P29	MDA5
M A DQ6	T29	MDA6
M A DQ7	T30	MDA7
M A DM0	T29	DQMA0
M A DQS0	R27	DQSA0
M A DQS#0	R26	DQSA0#
M A DQ8	T26	MDA8
M A DQ9	V26	MDA9
M A DQ10	W23	MDA10
M A DQ11	W22	MDA11
M A DQ12	U23	MDA12
M A DQ13	T24	MDA13
M A DQ14	Y23	MDA14
M A DQ15	Y22	MDA15
M A DM1	Y22	DQMA1
M A DQS1	V23	DQSA1
M A DQS#1	V24	DQSA1#
M A DQ16	W30	MDA16
M A DQ17	U25	MDA17
M A DQ18	Y29	MDA18
M A DQ19	Y30	MDA19
M A DQ20	V30	MDA20
M A DQ21	V29	MDA21
M A DQ22	Y28	MDA22
M A DQ23	Y28	MDA23
M A DM2	V28	DQMA2
M A DQS2	W27	DQSA2
M A DQS#2	W26	DQSA2#
M A DQ24	Y26	MDA24
M A DQ25	A23	MDA25
M A DQ26	AB22	MDA26
M A DQ27	AE26	MDA27
M A DQ28	Y24	MDA28
M A DQ29	AB26	MDA29
M A DQ30	AC26	MDA30
M A DQ31	AC26	MDA31
M A DM3	AB24	DQMA3
M A DQS3	AC23	DQSA3
M A DQS#3	AB23	DQSA3#
M A DQ32	AF25	MDA32
M A DQ33	AC21	MDA33
M A DQ34	AF20	MDA34
M A DQ35	AG24	MDA35
M A DQ36	AF26	MDA36
M A DQ37	AF24	MDA37
M A DQ38	AF22	MDA38
M A DQ39	AD20	MDA39
M A DM4	AC20	DQMA4
M A DQS4	AC22	DQSA4
M A DQS#4	AD22	DQSA4#
M A DQ40	AK24	MDA40
M A DQ41	AG21	MDA41
M A DQ42	AK21	MDA42
M A DQ43	AK20	MDA43
M A DQ44	AF23	MDA44
M A DQ45	AG23	MDA45
M A DQ46	AK23	MDA46
M A DQ47	AK22	MDA47
M A DM5	AF21	DQMA5
M A DQS5	AH22	DQSA5
M A DQS#5	AJ22	DQSA5#
M A DQ48	AB19	MDA48
M A DQ49	AB20	MDA49
M A DQ50	AF18	MDA50
M A DQ51	AD16	MDA51
M A DQ52	AD18	MDA52
M A DQ53	AC19	MDA53
M A DQ54	AB17	MDA54
M A DQ55	AF16	MDA55
M A DM6	AC17	DQMA6
M A DQS6	AB18	DQSA6
M A DQS#6	AC18	DQSA6#
M A DQ56	AH20	MDA56
M A DQ57	AJ20	MDA57
M A DQ58	AG17	MDA58
M A DQ59	AK17	MDA59
M A DQ60	AF19	MDA60
M A DQ61	AG19	MDA61
M A DQ62	AH18	MDA62
M A DQ63	AF17	MDA63
M A DM7	AK19	DQMA7
M A DQS7	AJ18	DQSA7
M A DQS#7	AK18	DQSA7#

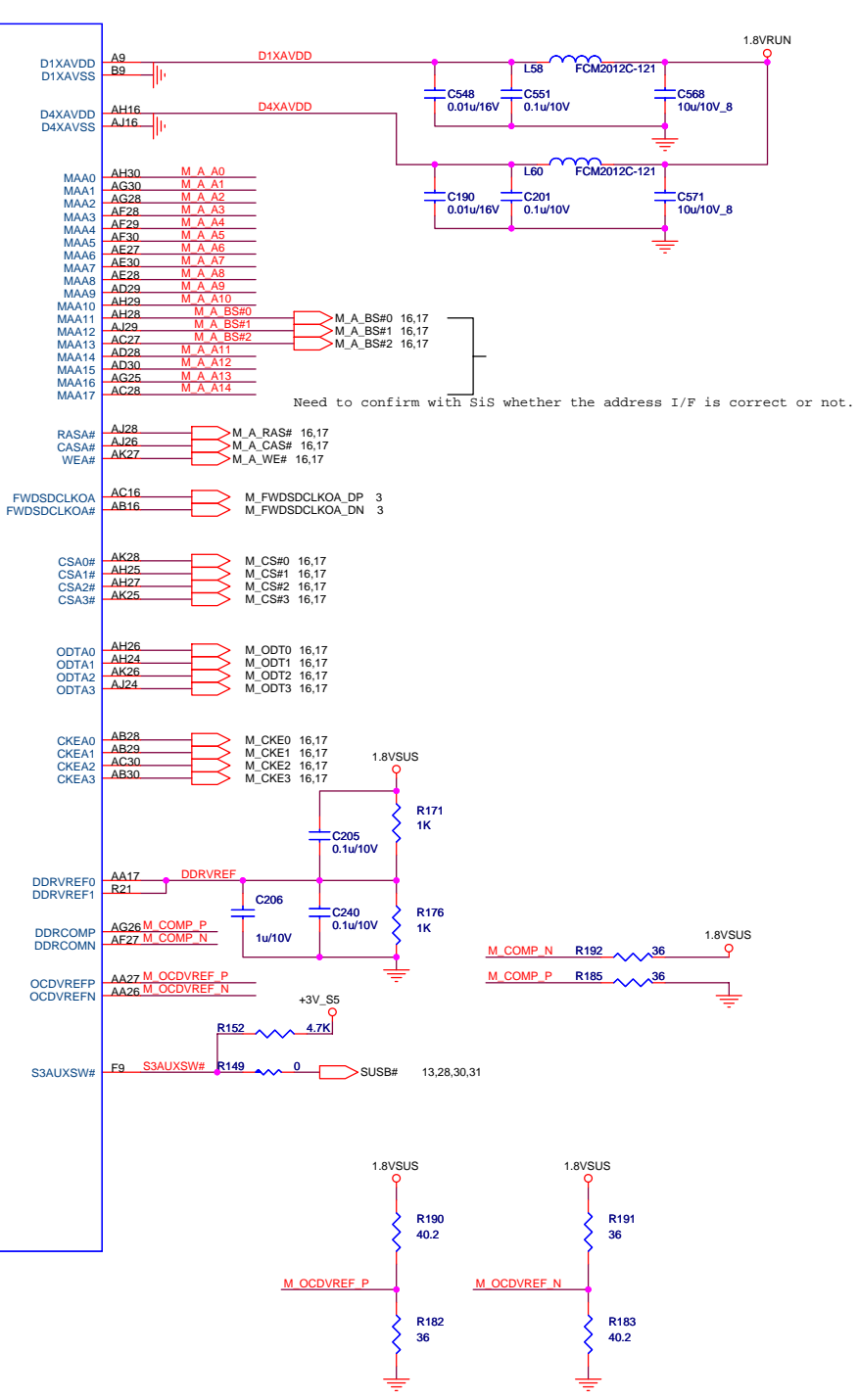

QUANTA COMPUTER

Title: **M662MX(DDRII)**

Size: Custom Document Number: **BQ2L MAIN BOARD** Rev: 1A

Date: Friday, August 25, 2006 Sheet: 8 of 38

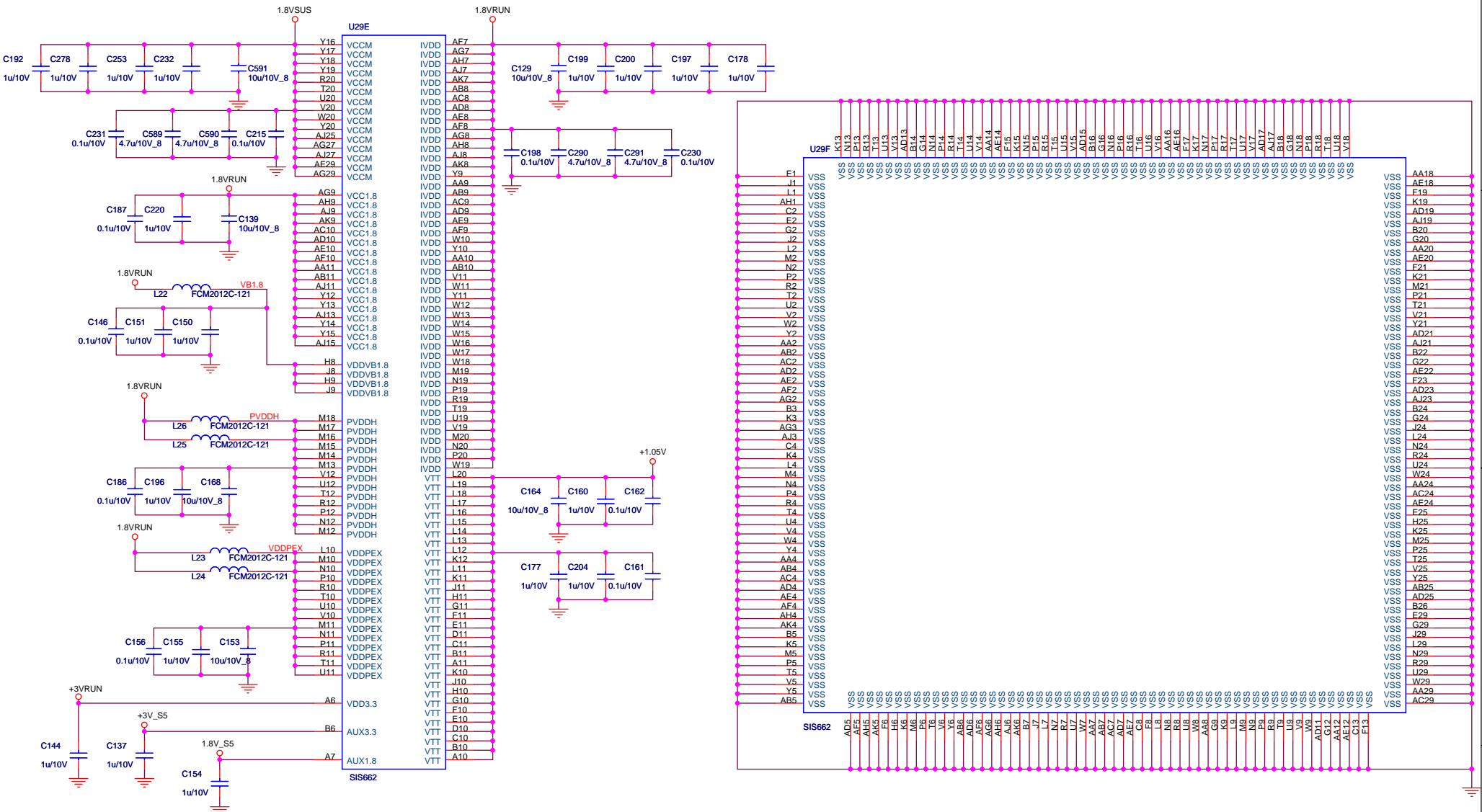

QUANTA COMPUTER

Title: **M662MX POWER, GND**

Size: Custom Document Number: **BQ2L MAIN BOARD** Rev: 1A

Date: Friday, August 25, 2006 Sheet: 9 of 38

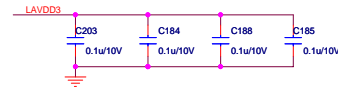
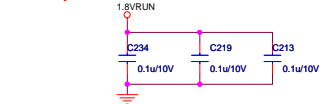
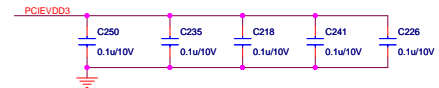
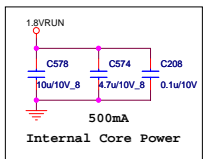
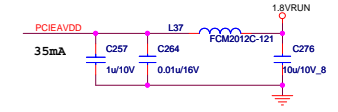
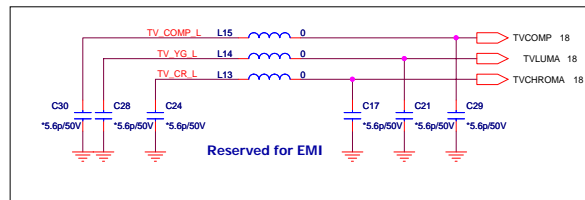
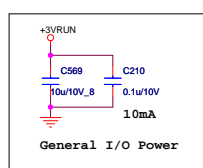
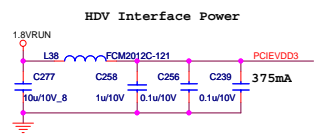

DINTN R160 '0' INTA# 6,7,12

INTA# pin is used on 307 only

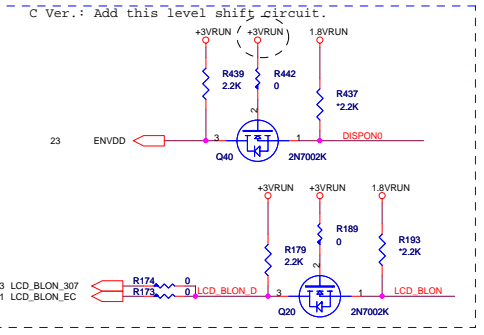
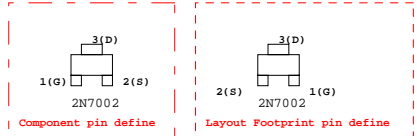
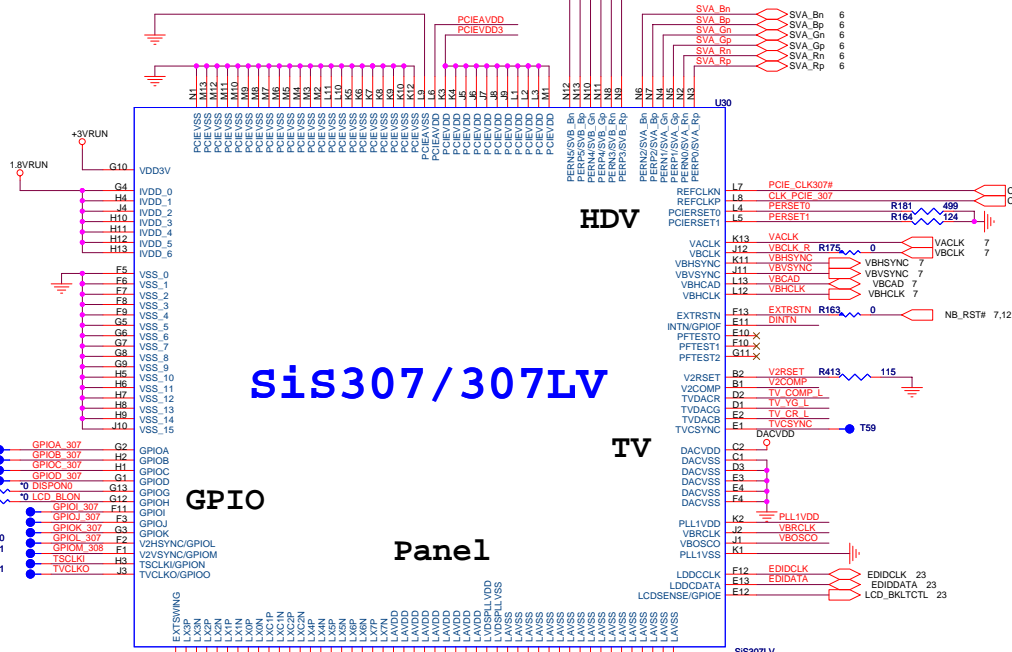
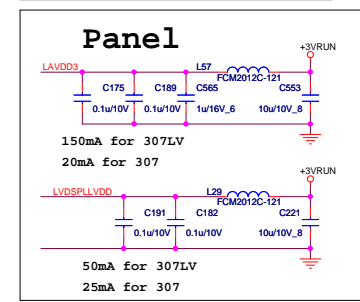
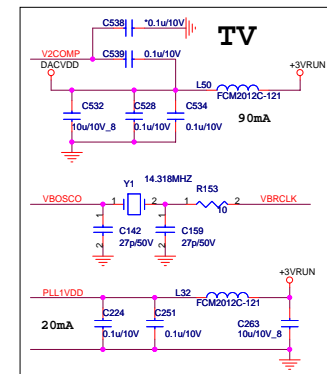

SIS307ELV: AJ003070T05(W/O TV); C-Test

SIS307LV: AJ003070T13 (With TV); A, B-Test

Power On sequence

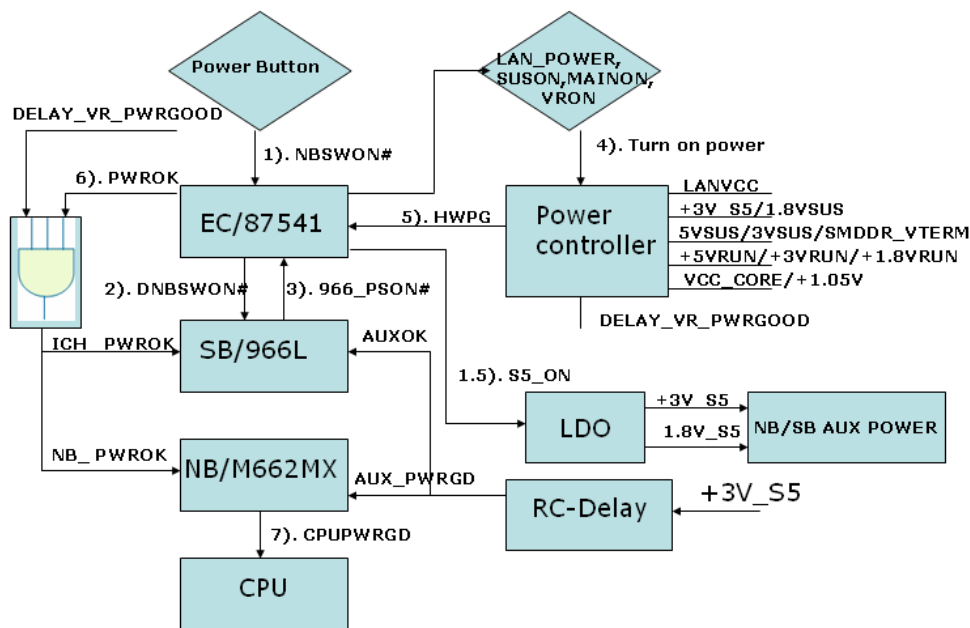

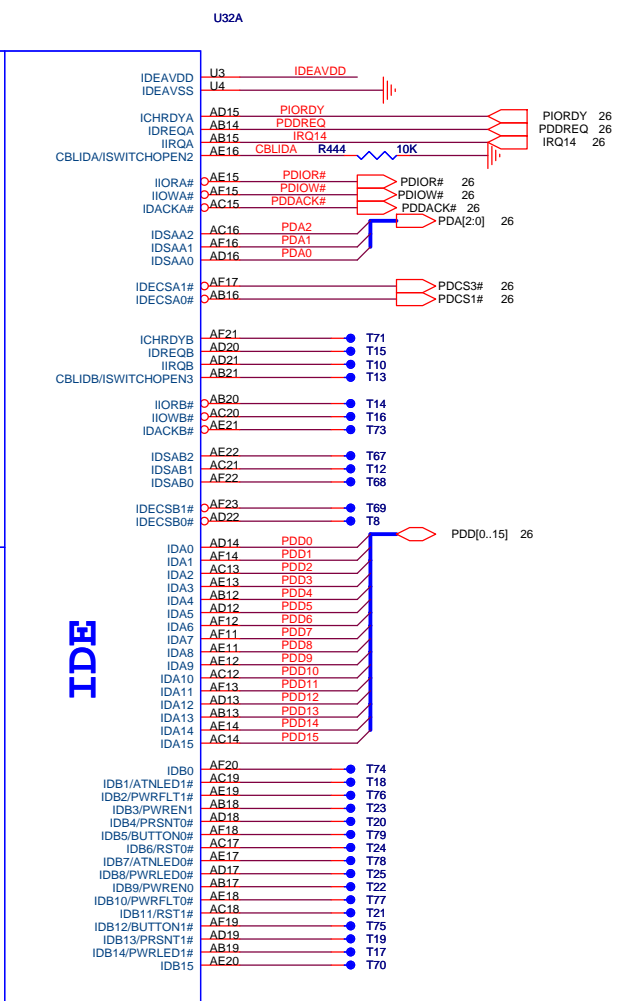
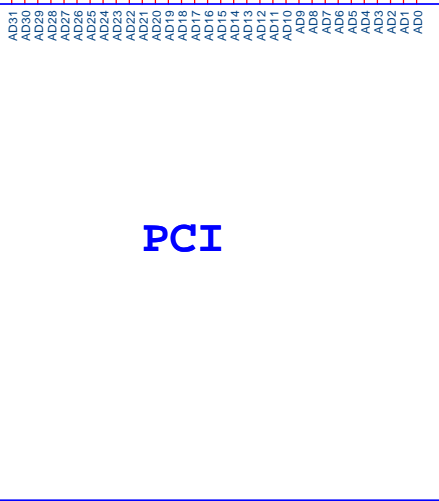
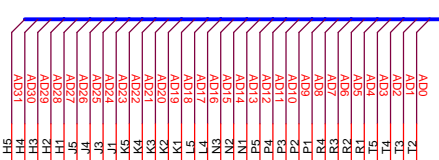
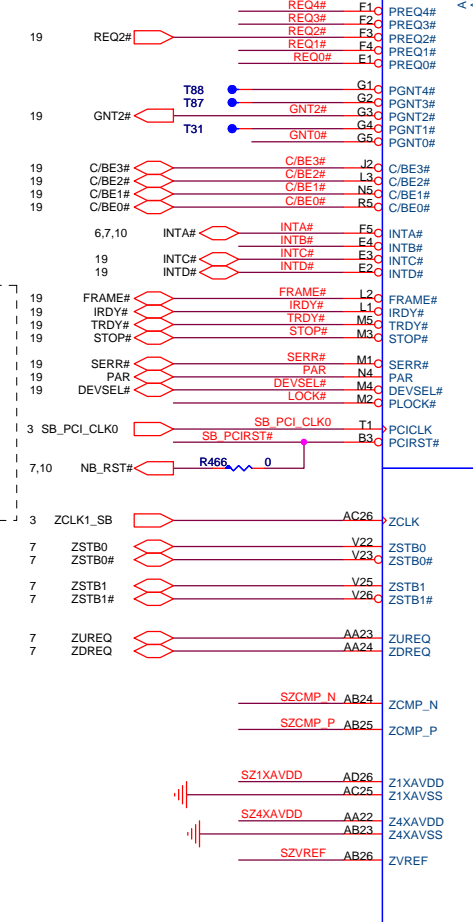
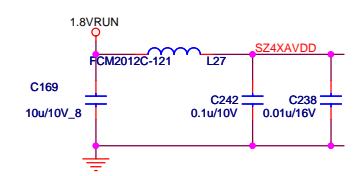
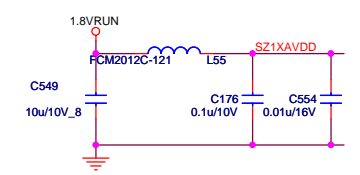
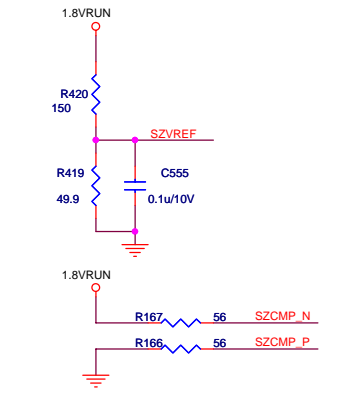
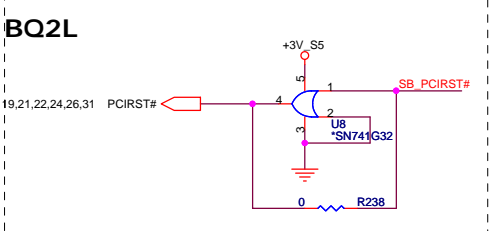
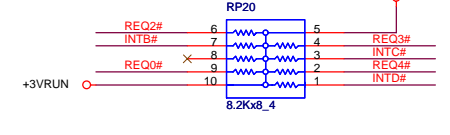
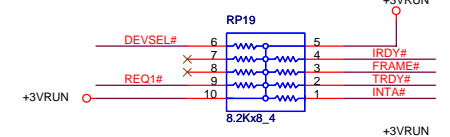
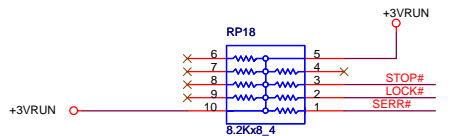

PCI

MuTIOL

Rev.B Added for Sis SB request



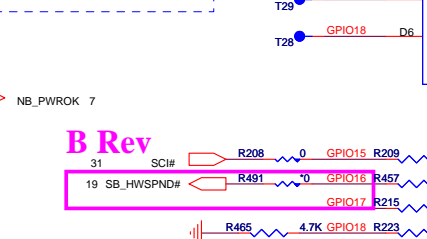
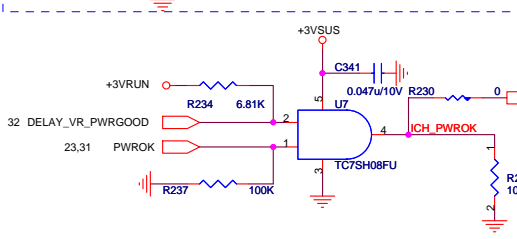
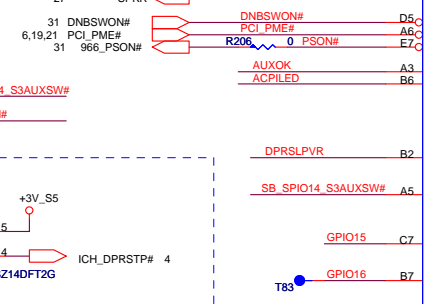
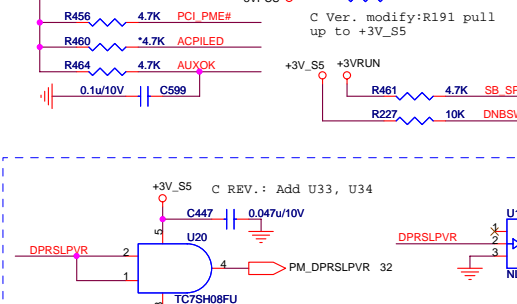
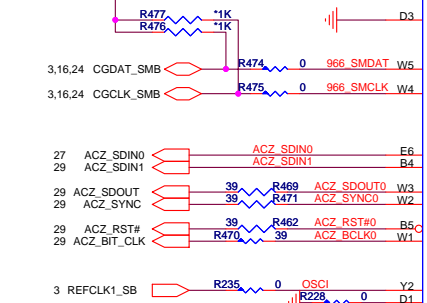
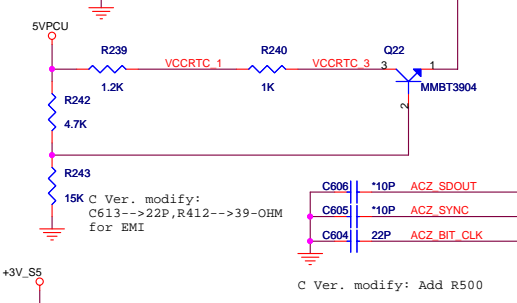
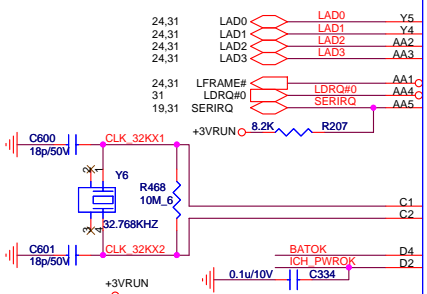
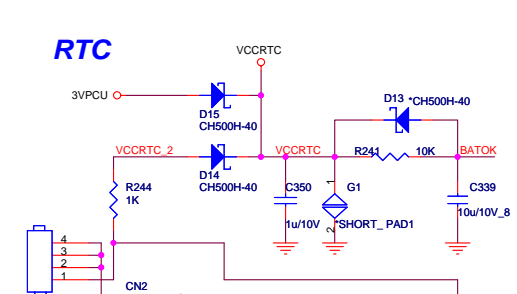
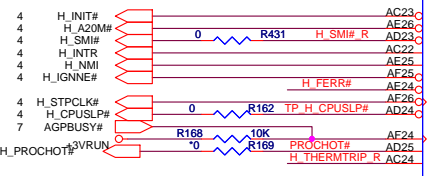
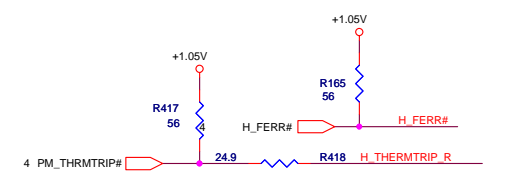

CPU_S

APIC

LPC

RTC

SMBUS

PCI Express

AC'97/HD Audio

ACPI/Others

GPIO Keyboard / Mouse

Rev. B Added
 GPIO18--> PATA/SATA Mode Select
 High: PATA Model (Stuff R189, Unstuff R495)
 Low : SATA Model (Stuff R495, UnstuffR189)

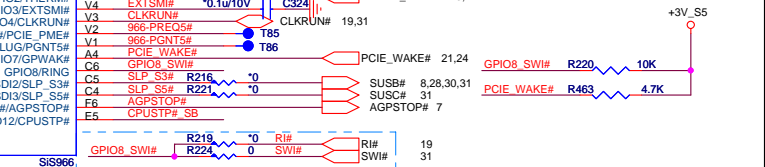
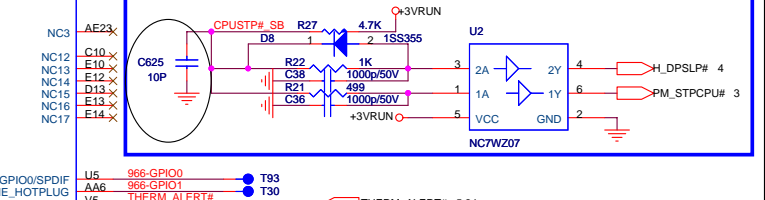
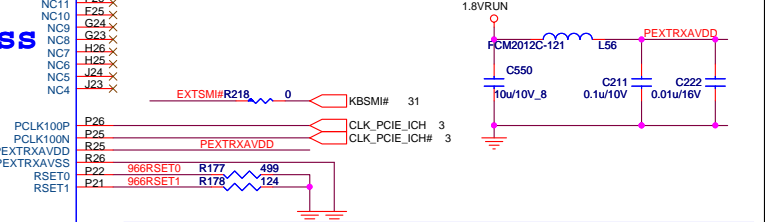
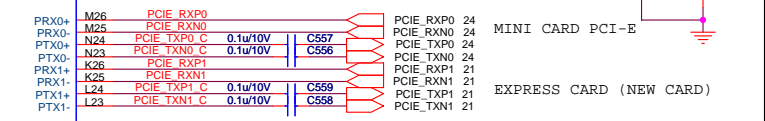
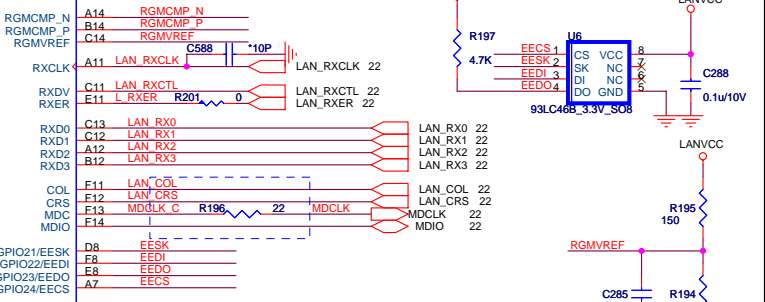
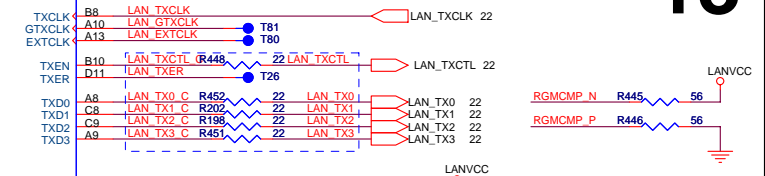

QUANTA COMPUTER

966 PCI E,LPC,MII,GPIO

BQ2L MAIN BOARD

Rev 1A

Date: Friday, August 25, 2006 Sheet 13 of 38

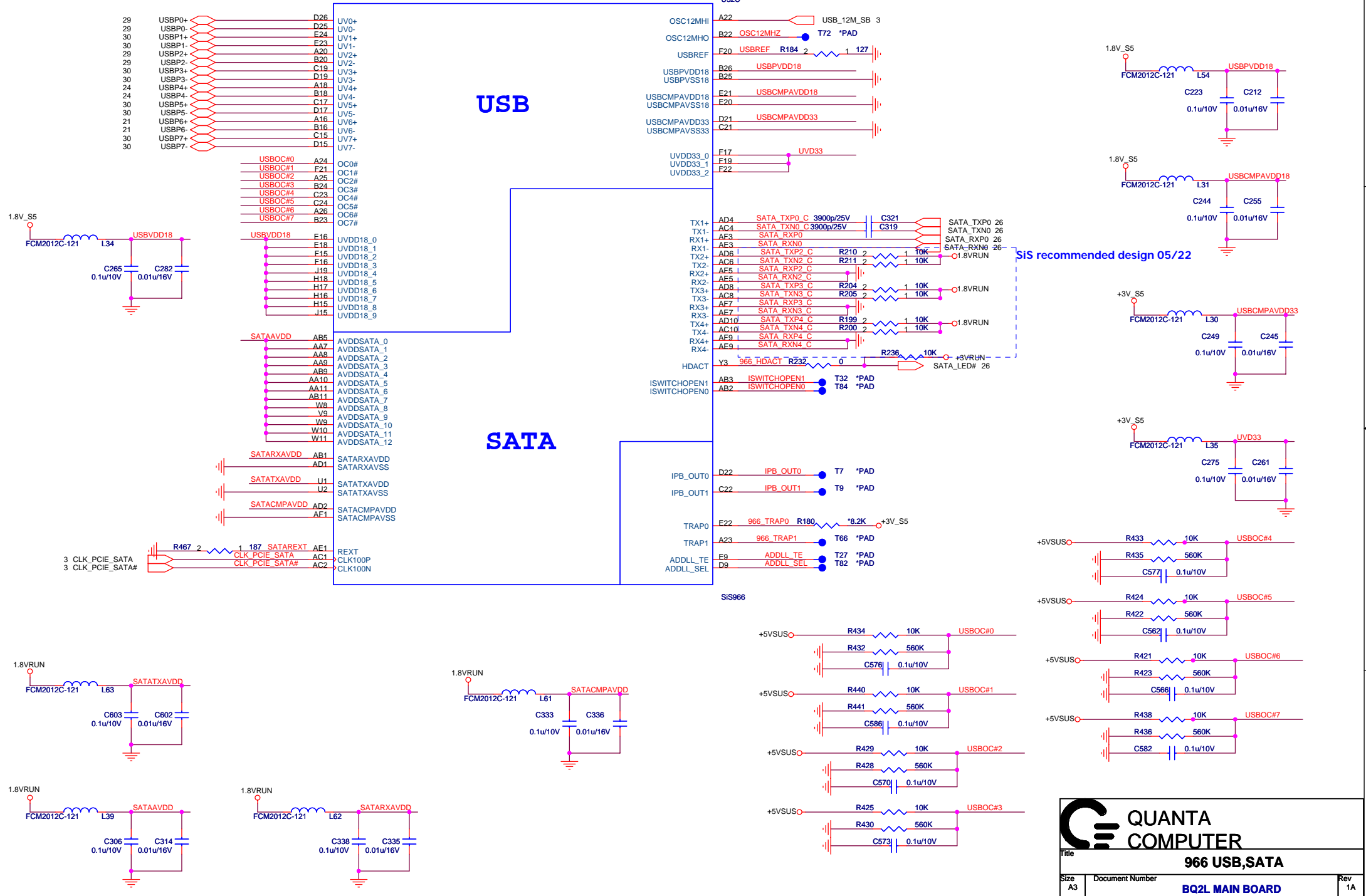

QUANTA COMPUTER

Title: **966 USB,SATA**

Size: A3 Document Number: **BQ2L MAIN BOARD** Rev: 1A

Date: Friday, August 25, 2006 Sheet: 14 of 38

DDRII SINGLE CHANNEL.

DDRII DIMM 1

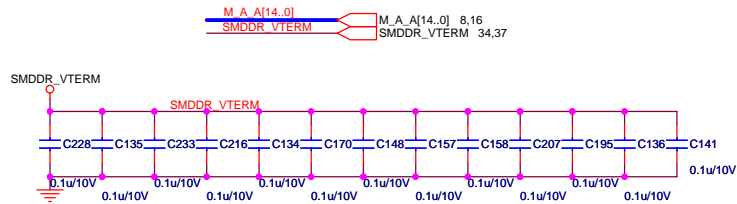

DDRII DIMM 2

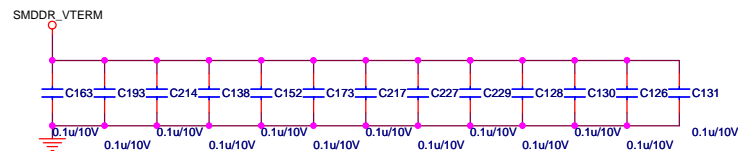

Layout note: Place one cap close to every 2 pullup resistors terminated to SMDRR_VTERM

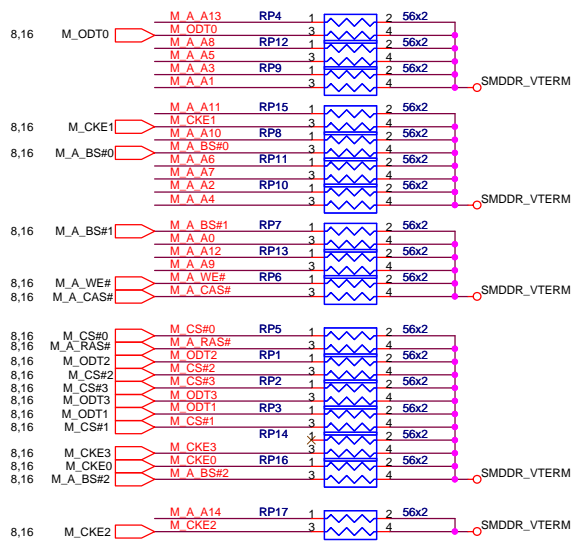

 QUANTA COMPUTER			
Title DDRII TERMINATION			
Size Custom	Document Number BQ2L MAIN BOARD	Rev 1A	
Date: Friday, August 25, 2006	Sheet	17	of 38

S-VIDEO

SiS recommended design 05/22
Close SiS 307LV

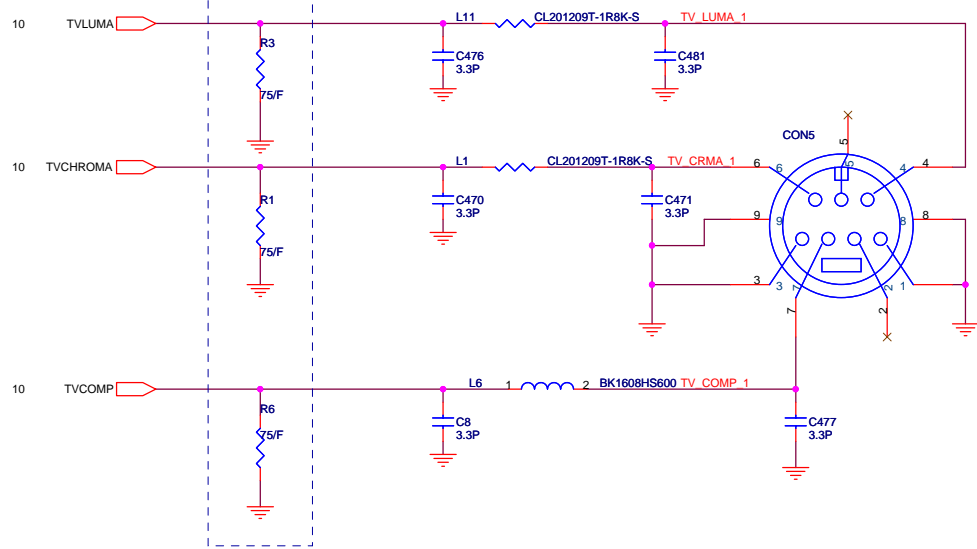

030001FR007T200FT
SV-030107FR007S112XR-RVS-7P

1/23 for Qpresentation SW
program on wide screen projector

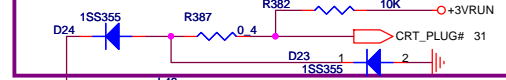

CRT PORT

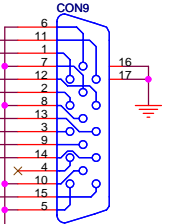

SiS recommended design 05/22

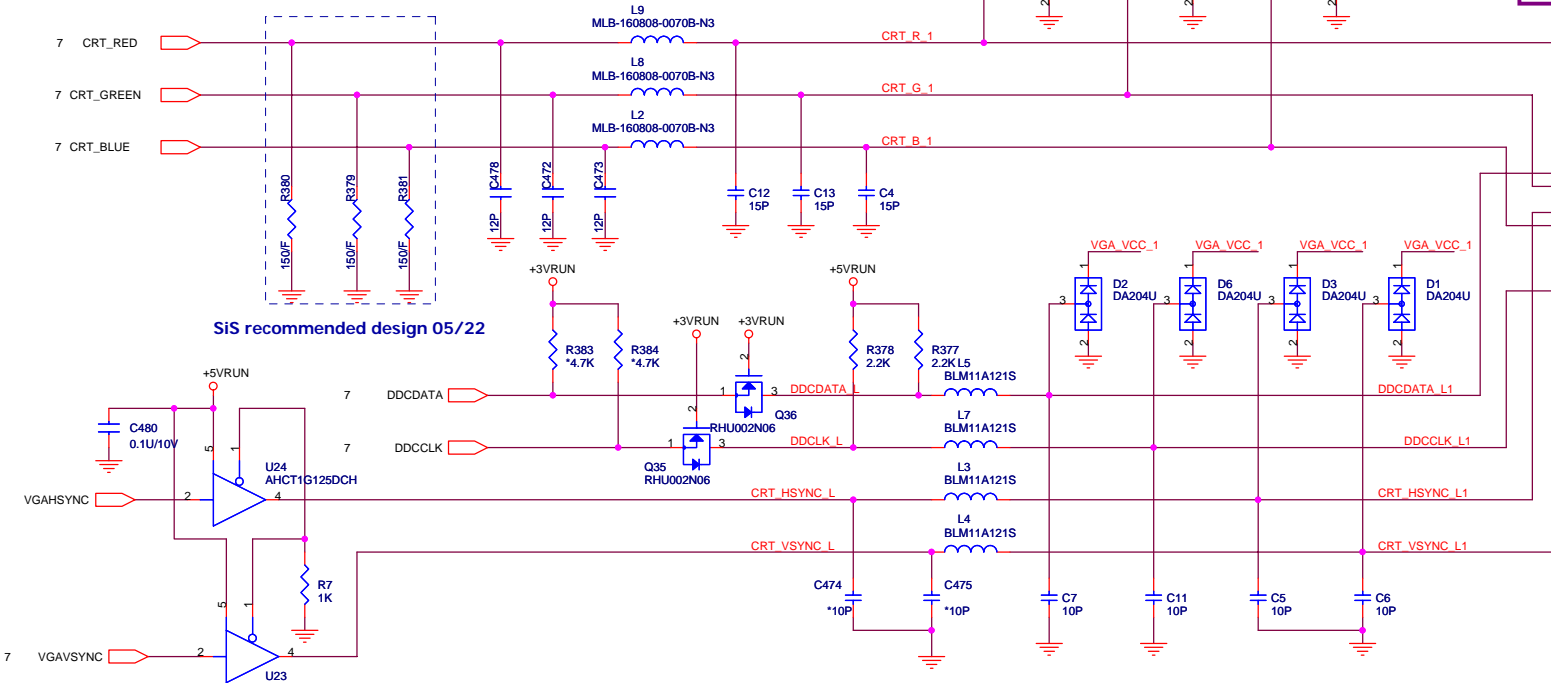

QUANTA COMPUTER

File: **CRT&S-VIDEO**

Size: Custom	Document Number: BQ2L MAIN BOARD	Rev: 1A
Date: Friday, August 25, 2006	Sheet: 18 of 38	

Reserved function

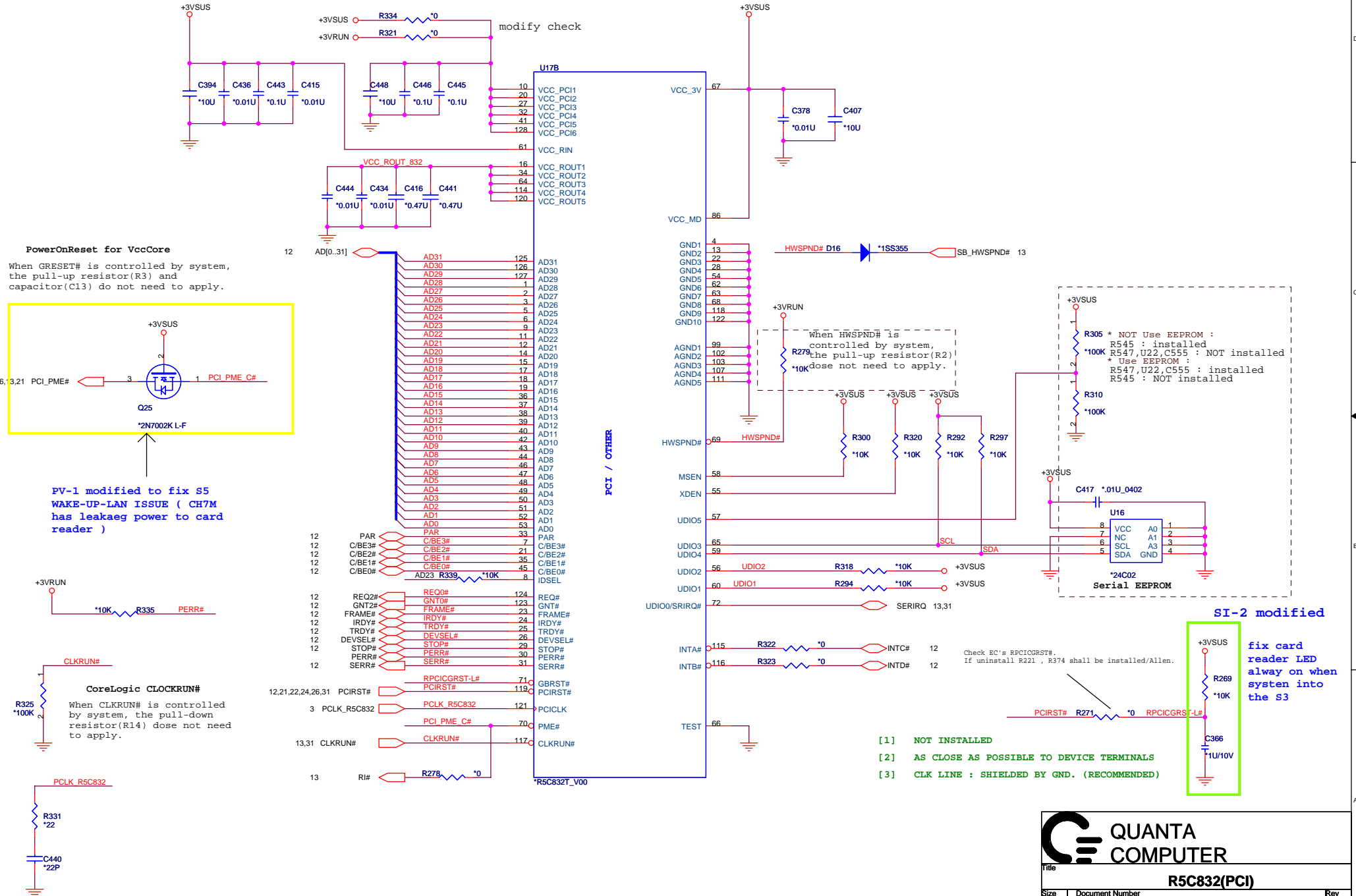

QUANTA COMPUTER

Title: **R5C832(PCI)**

Size: Custom Document Number: **BQ2L MAIN BOARD** Rev: 1A

Date: Friday, August 25, 2006 Sheet: 19 of 38

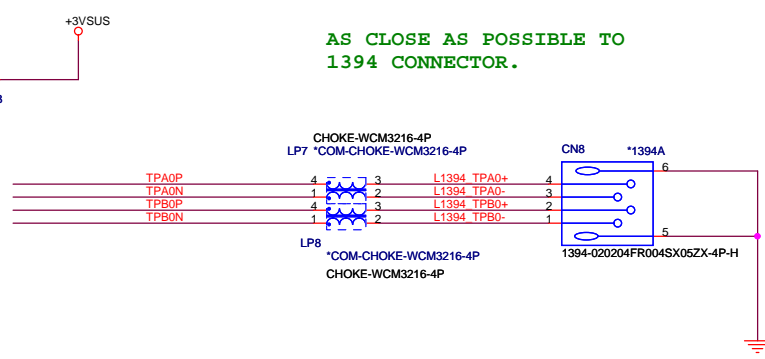
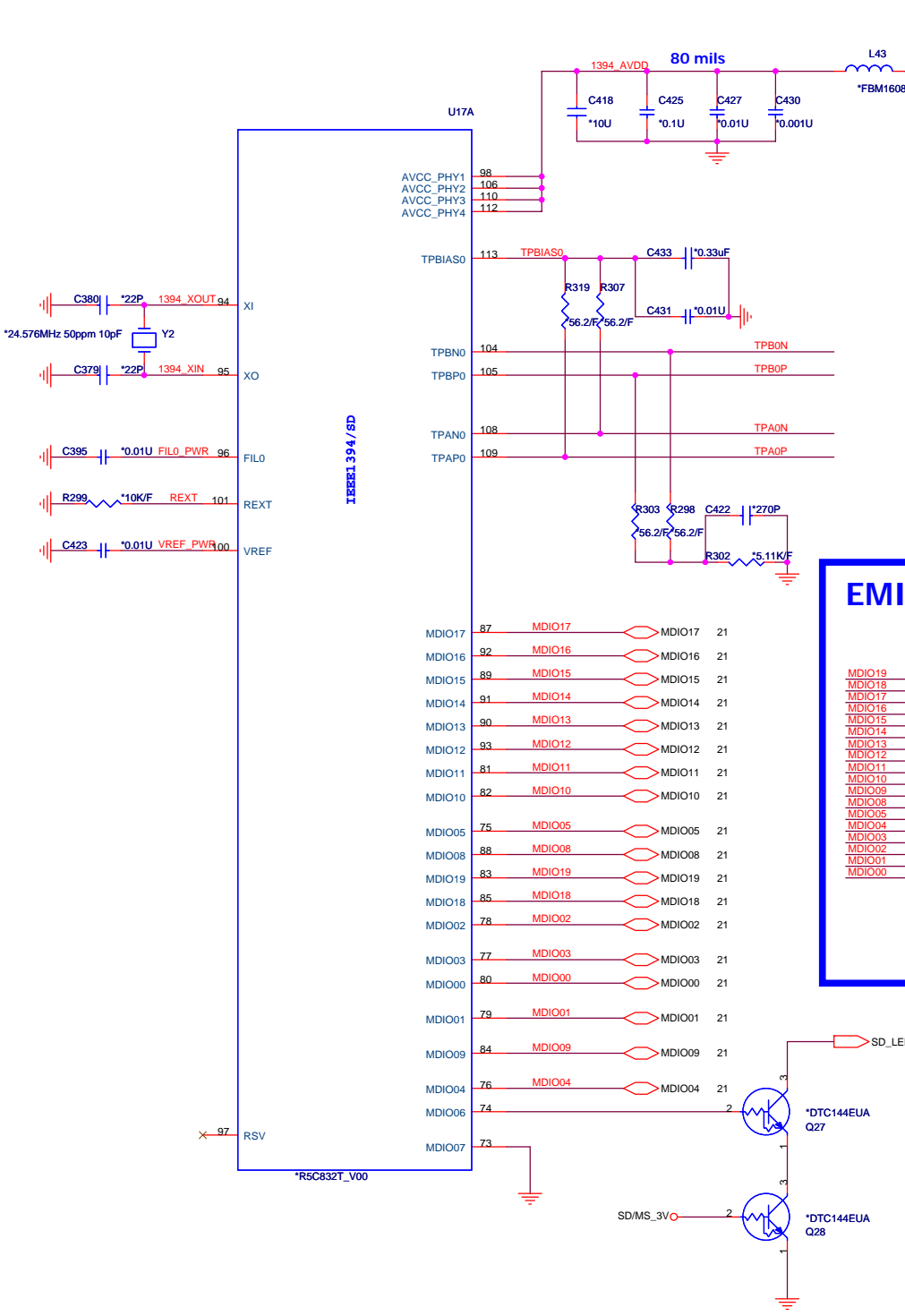

*TPA/TPA#,TPB/TPB# pair trace : As close as possible.
 *TPA/TPA#,TPB/TPB# pair trace : Same length electrically.
 *Termination resistor for TPA+/- TPB+/- : As close as possible to its cable driver (device pin out).

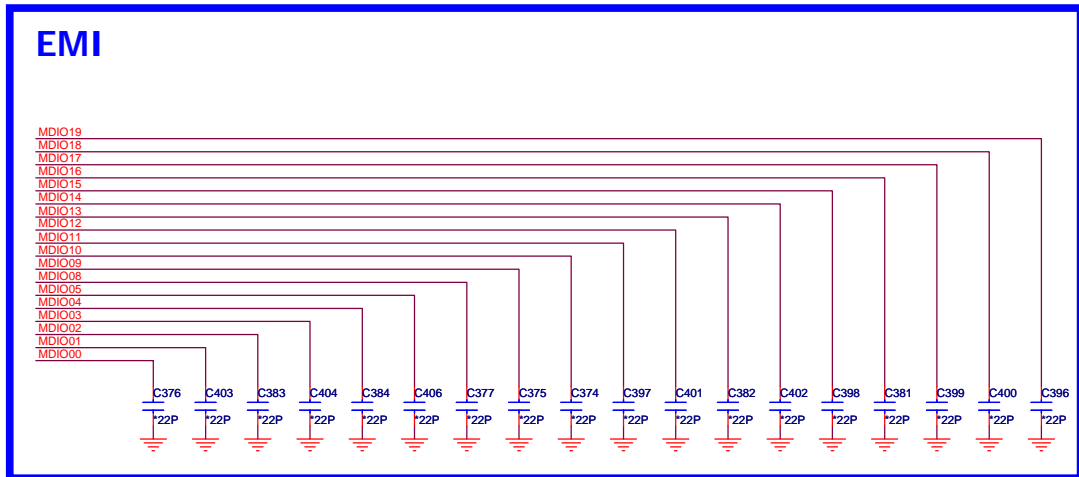

Reserved function

QUANTA COMPUTER

File: **R5C832(1394)**

Size: Custom Document Number: **BQ2L MAIN BOARD** Rev: 1A

Date: Friday, August 25, 2006 Sheet: 20 of 38

NEW CARD

21

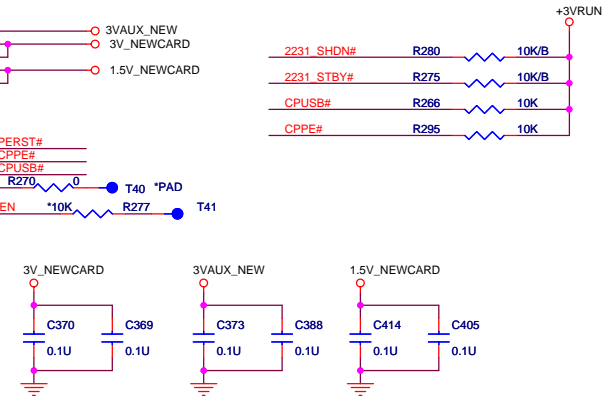
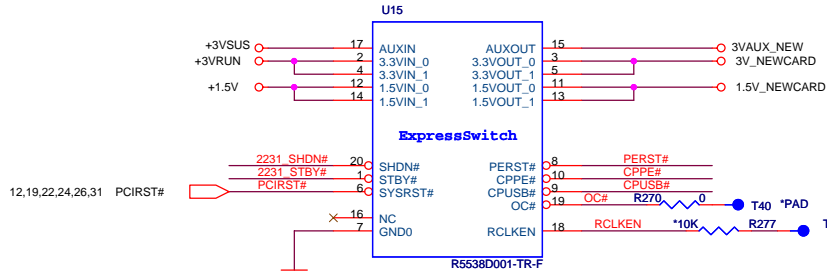
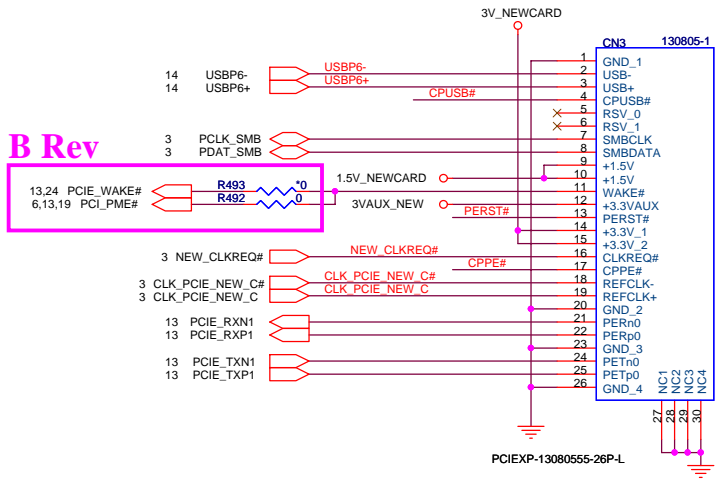

Reserved function CARD READER

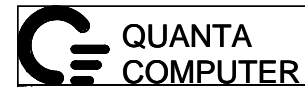
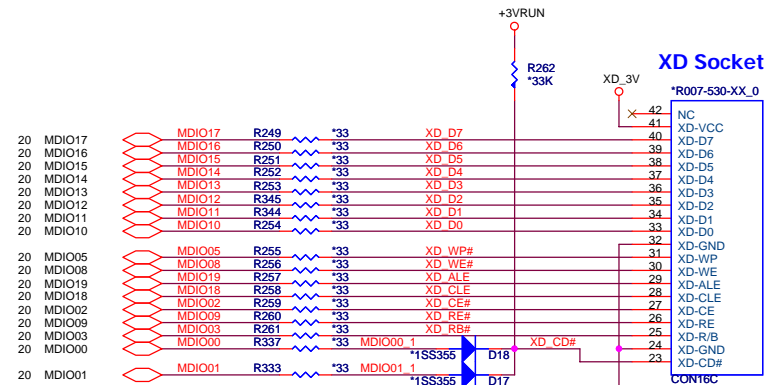
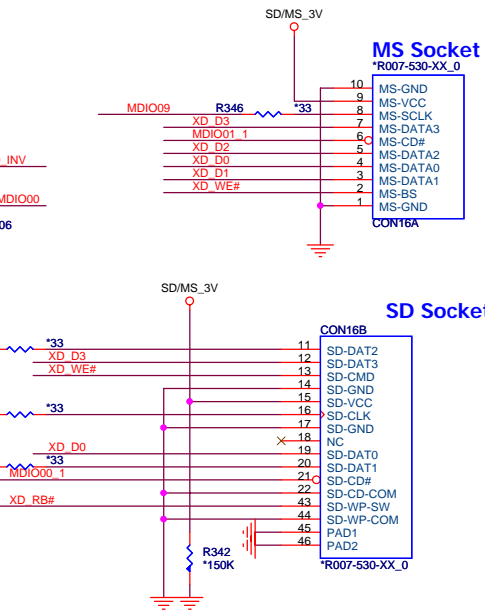
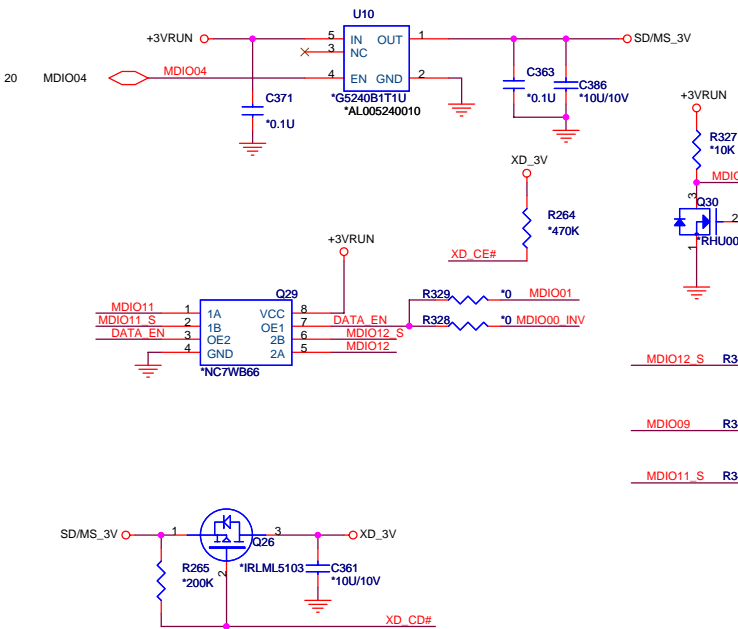

Title			R5C832(5 IN 1/NCARD)
Size	Document Number	Rev	
Custom	BQ2L MAIN BOARD	1A	
Date:	Friday, August 25, 2006	Sheet	21 of 38

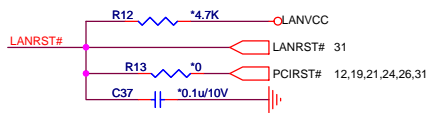
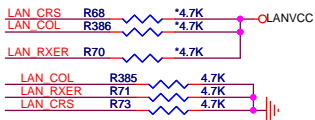
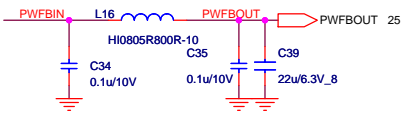
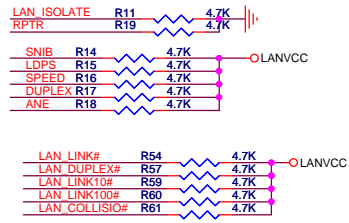
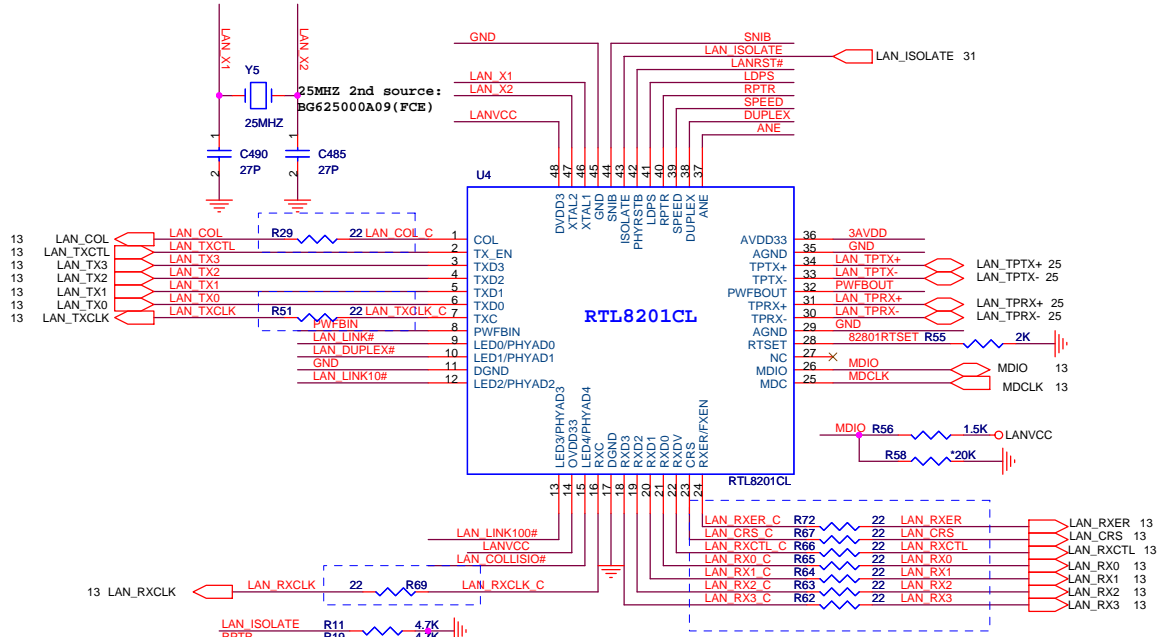

B-Add: LANVCC discharge circuit

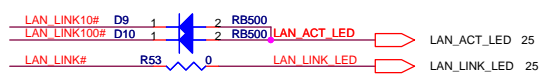
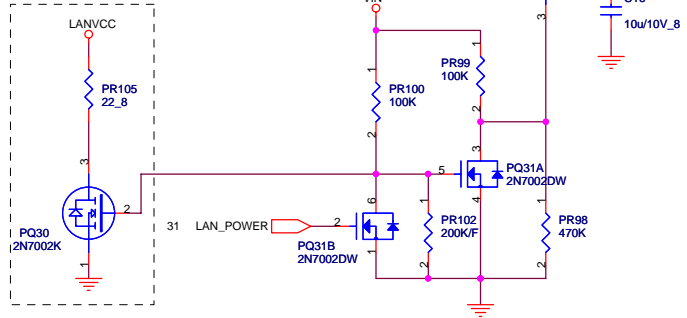

LAN_COL	1	Default	RTL8201BL LED
LAN_RXER_R	1	Default	RTL8201CL LED
LAN_LINK100#	1	Default	Fiber Mode
LAN_CRS	0	Default	Ensure operating at normal mode

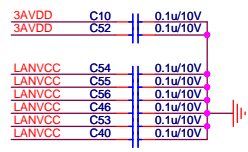
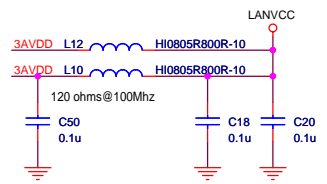

MINI PCI-E CARD

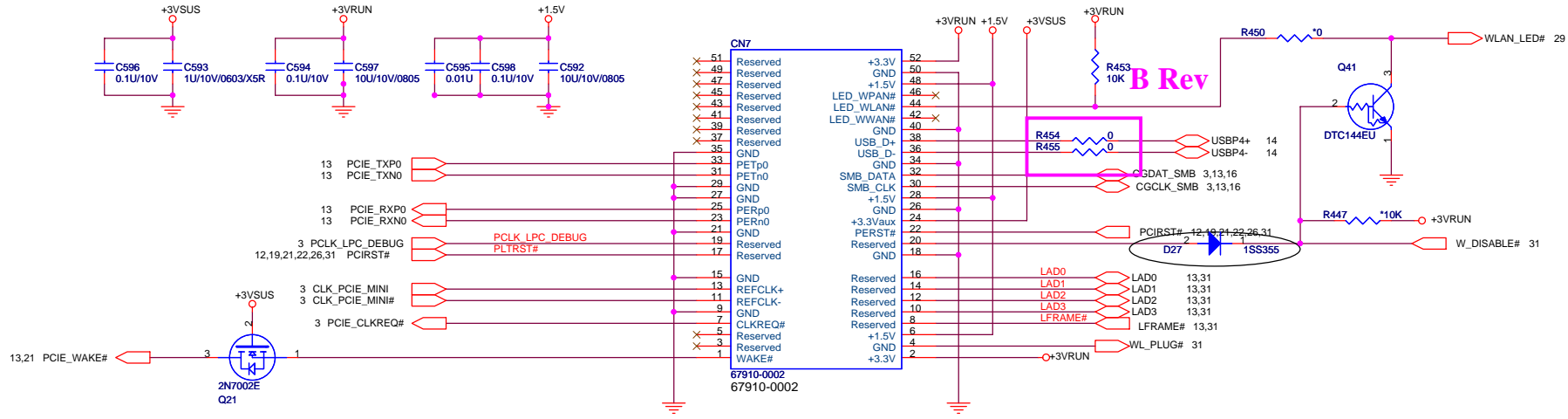

FAN CONN

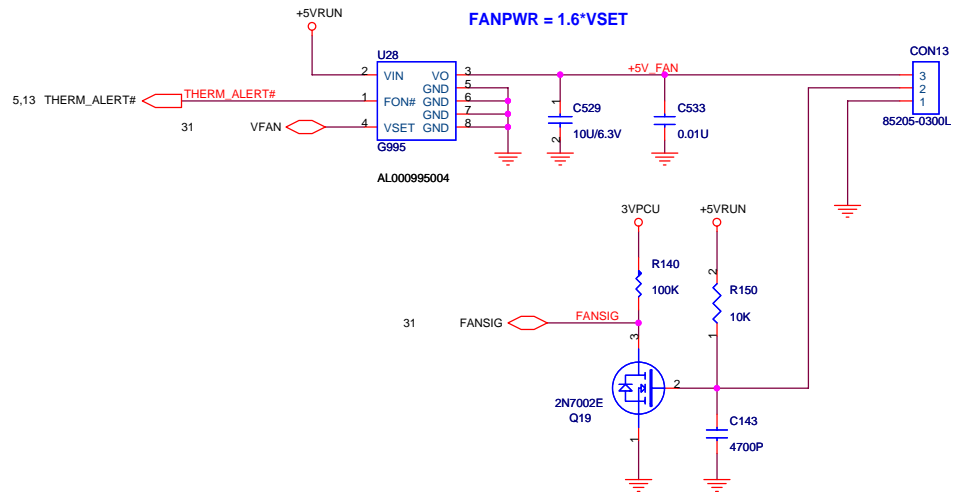

QUANTA COMPUTER

Title: **MINI PCIE/FAN**

Size: Custom Document Number: **BQ2L MAIN BOARD** Rev: 1A

Date: Friday, August 25, 2006 Sheet: 24 of 38

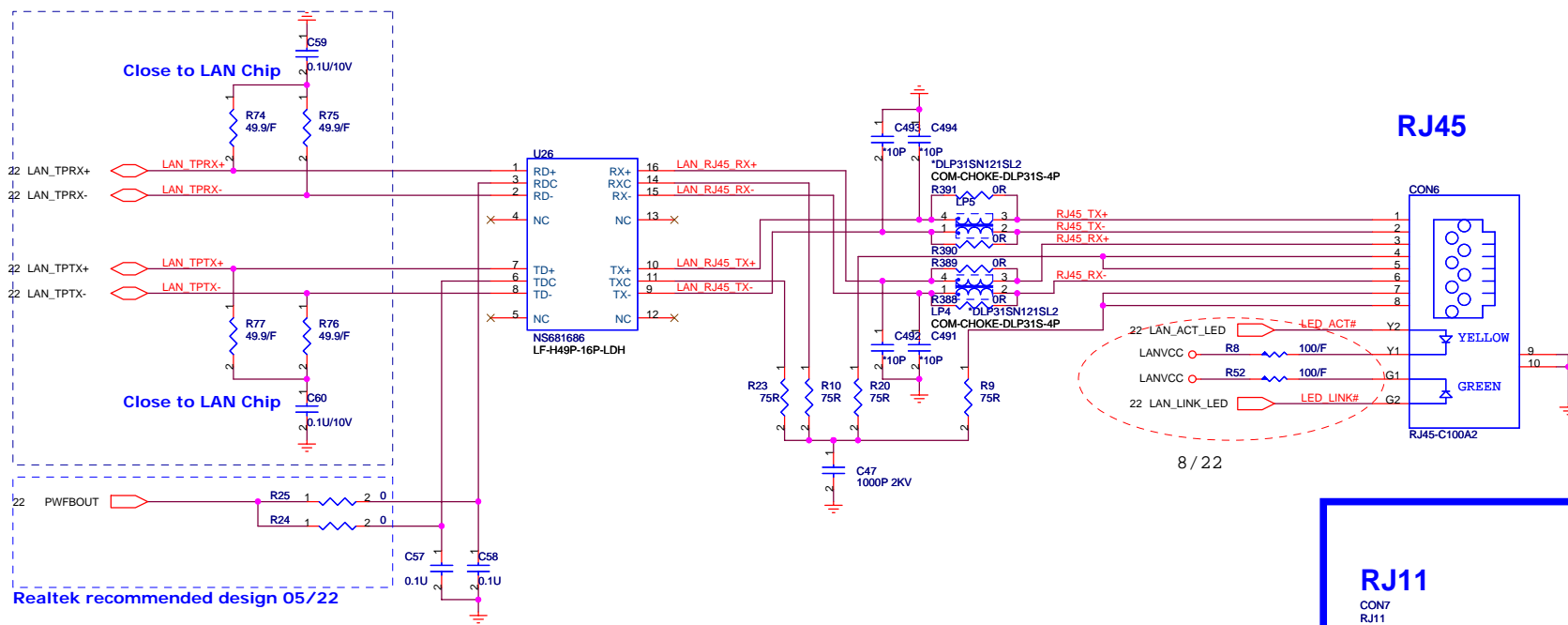

Realtek recommended design 05/22

8 / 22

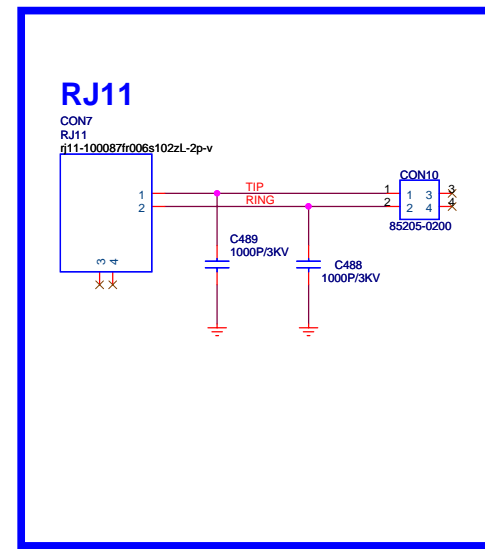

QUANTA COMPUTER			
Title		RJ45/RJ11	
Size	Document Number	Rev	
Custom	BQ2L MAIN BOARD	1A	
Date: Friday, August 25, 2006		Sheet	25 of 38

CD-ROM CONNECTOR SMT TYPE CNN

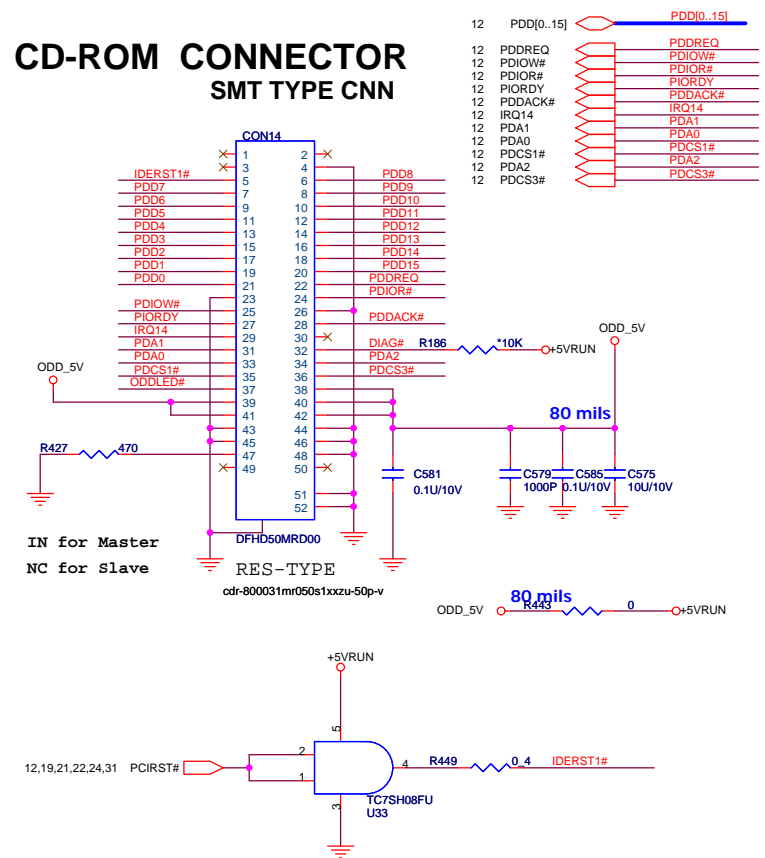

SATA HDD CONNECTOR

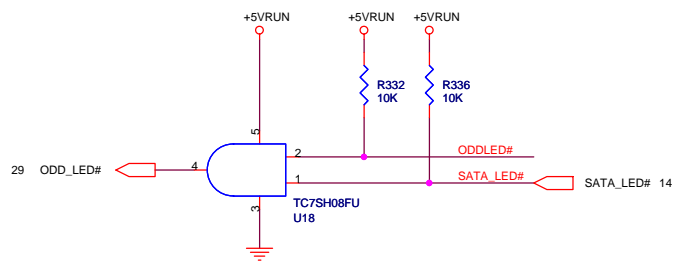
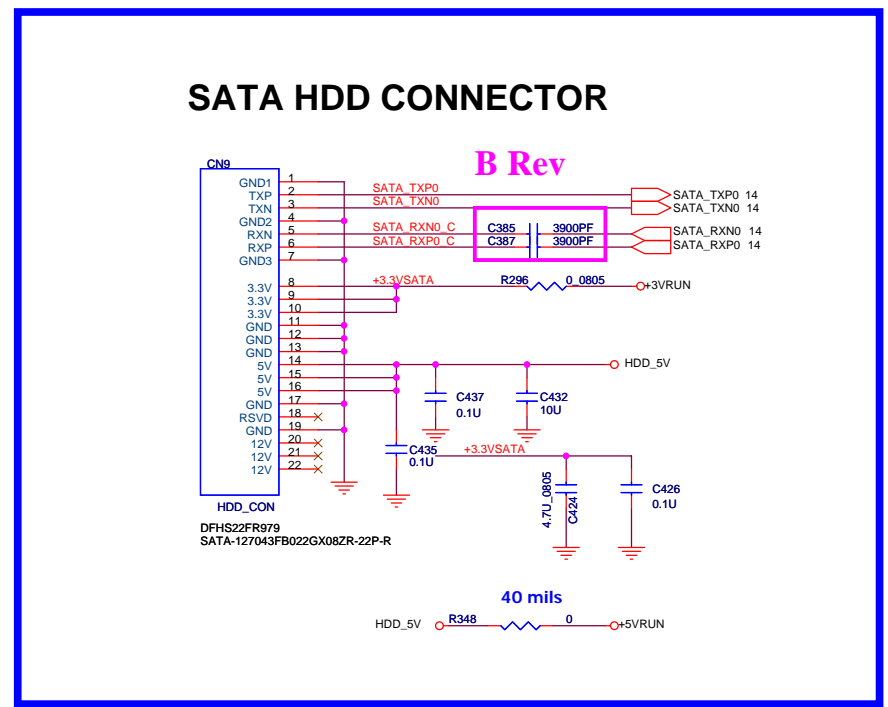

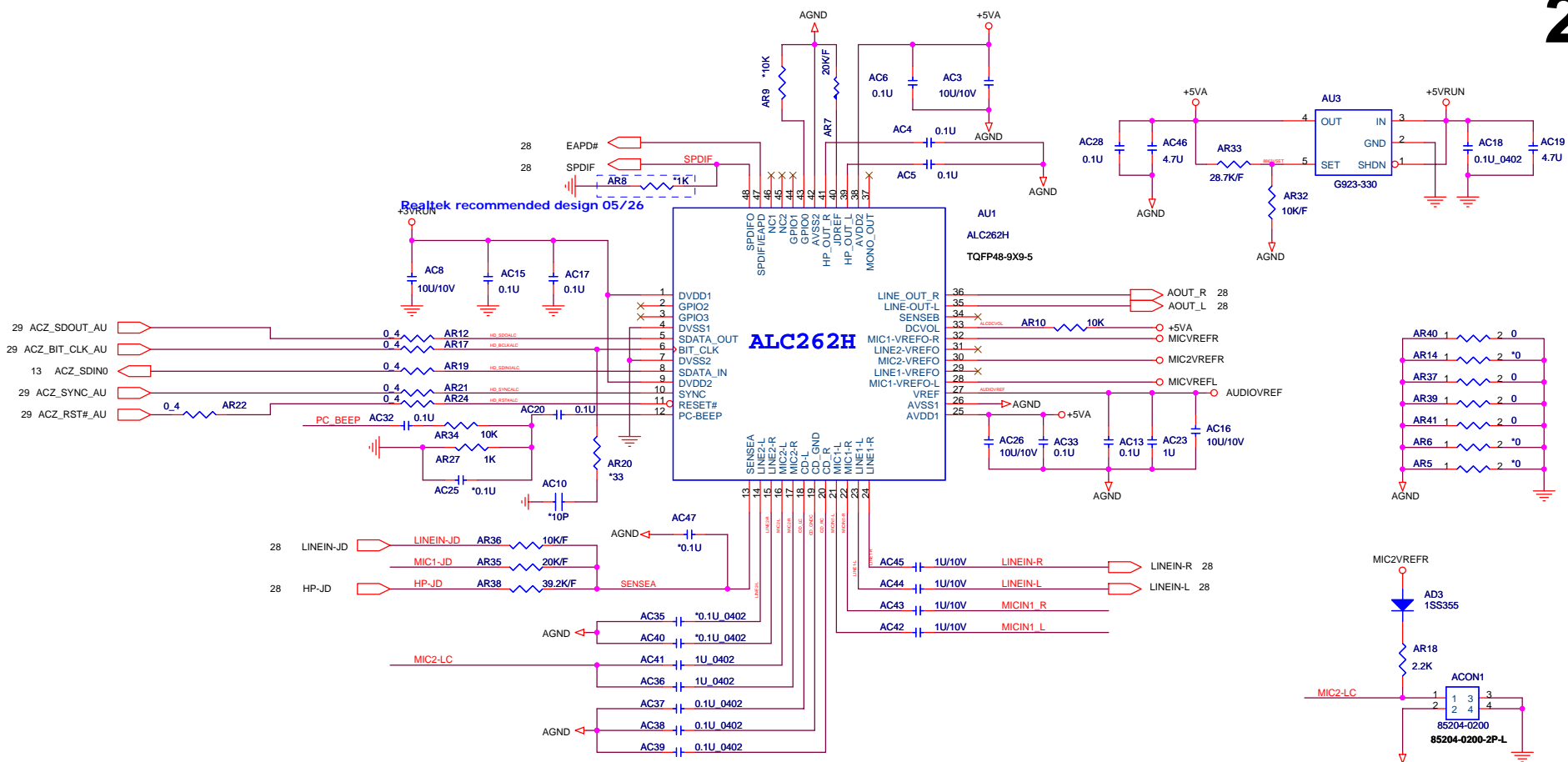

MIC IN EXT MIC(Pink)

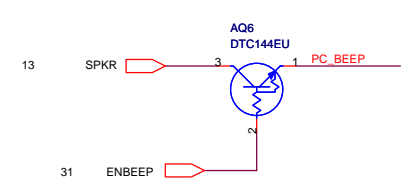
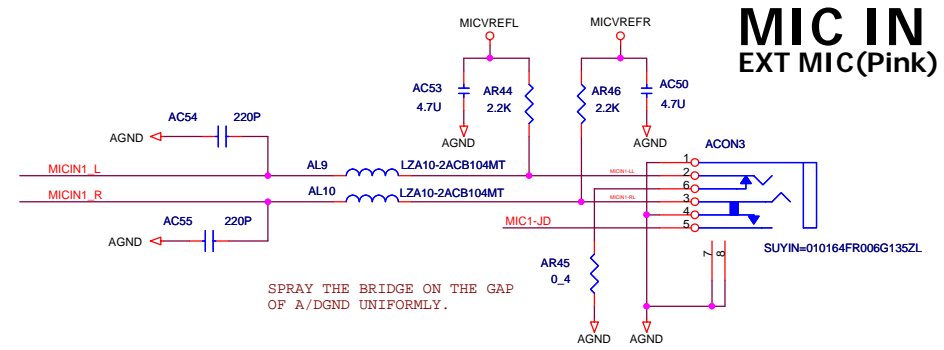

QUANTA COMPUTER

Title: **AUDIO(ALC262,MIC,HP)**

Size	Document Number	Rev
Custom	BQ2L MAIN BOARD	1A

Date: Friday, August 25, 2006 Sheet 27 of 38

GAIN	SPKR MODE	HP MODE
0	10.5	3
1	9	0

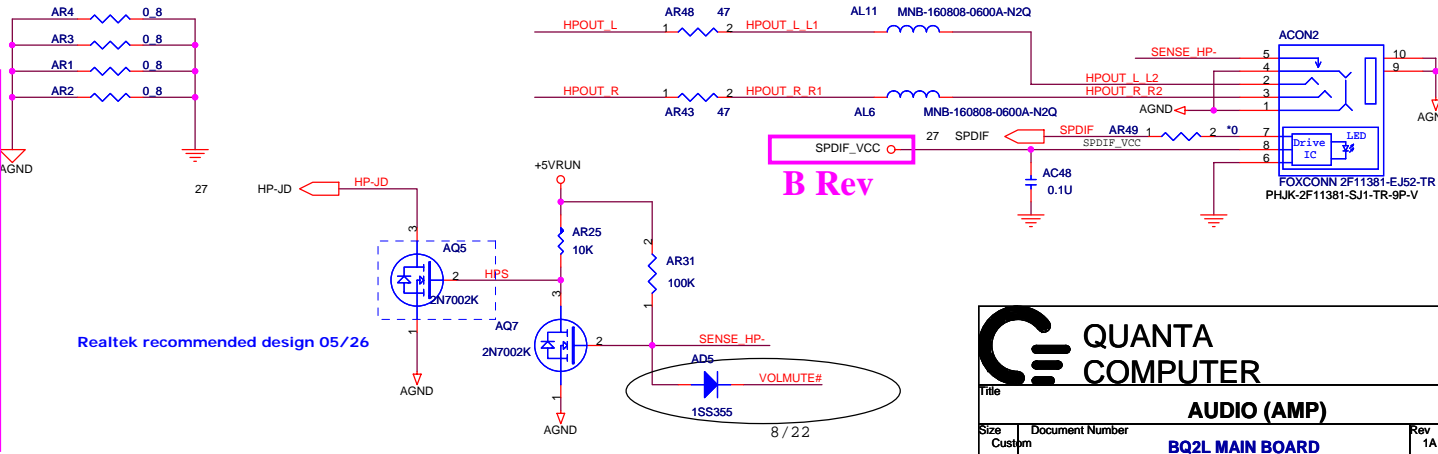
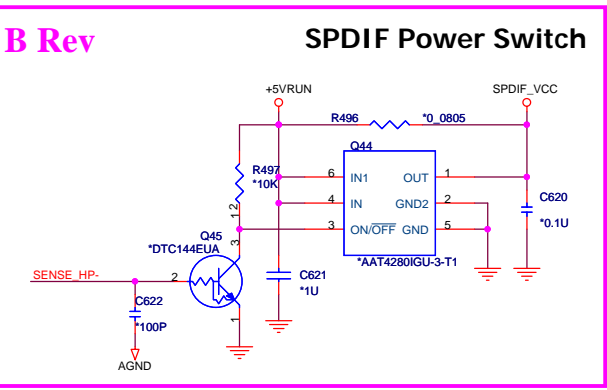
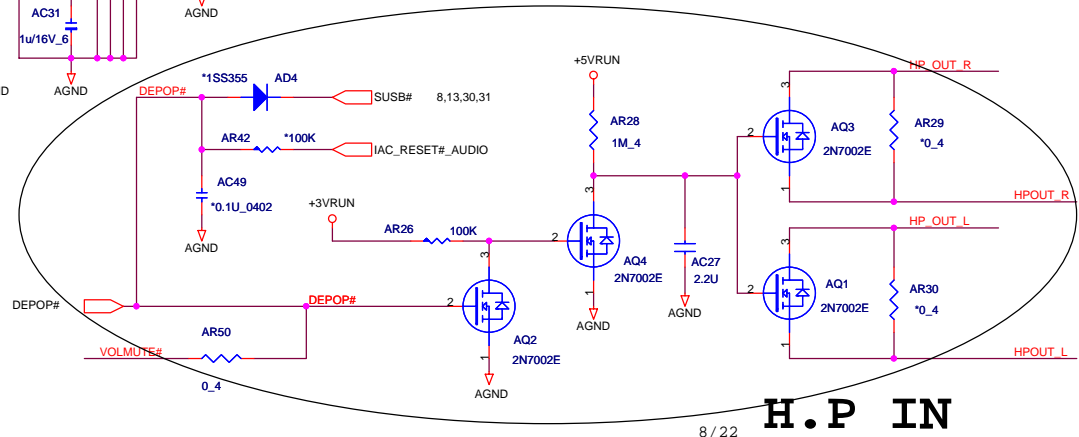
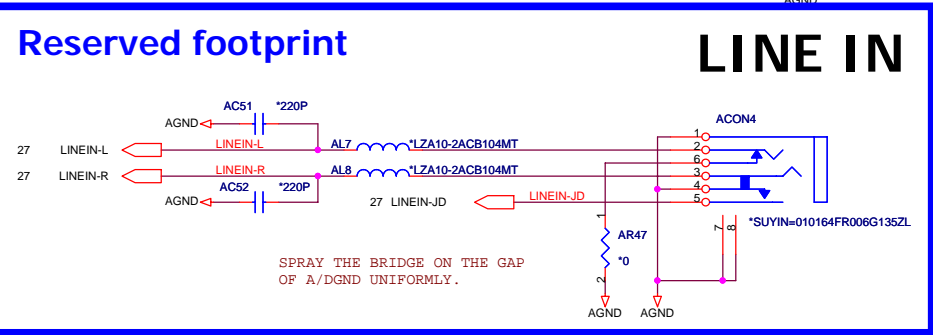
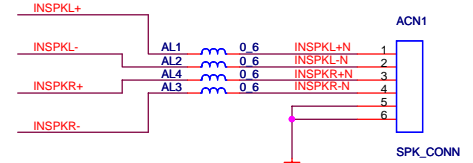
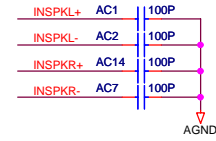
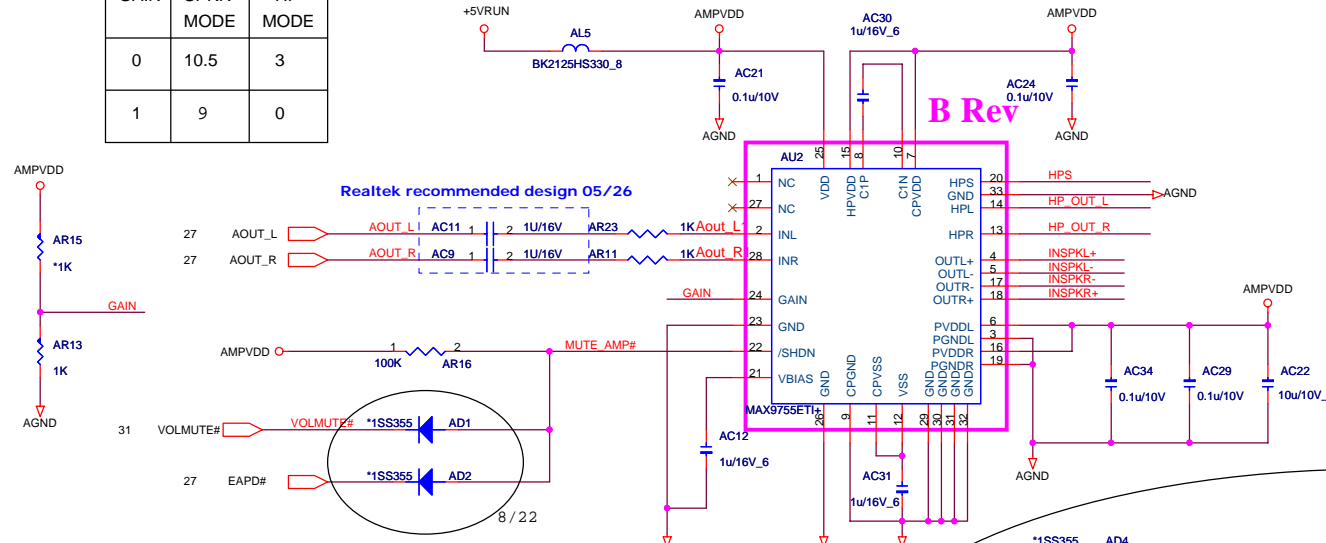

QUANTA COMPUTER

Title: **AUDIO (AMP)**

Size: Custom Document Number: **BQ2L MAIN BOARD** Rev: 1A

Date: Friday, August 25, 2006 Sheet: 28 of 38

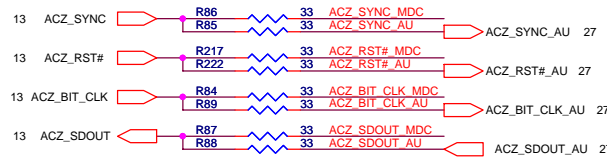

TOUCH PAD

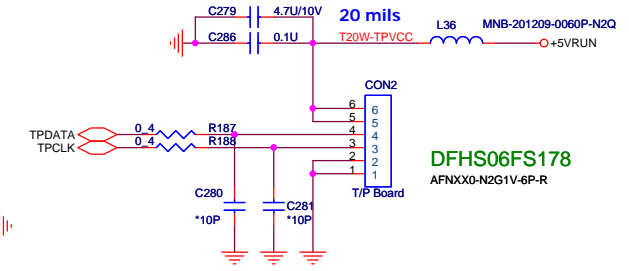

DFHS06FS178
AFNXX0-N2G1V-6P-R

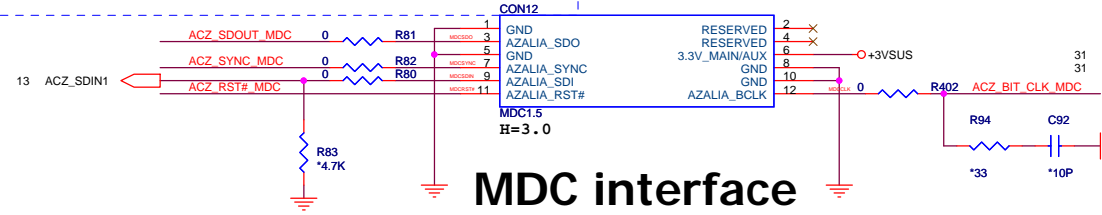

MDC interface

SWITCH/LED BOARD

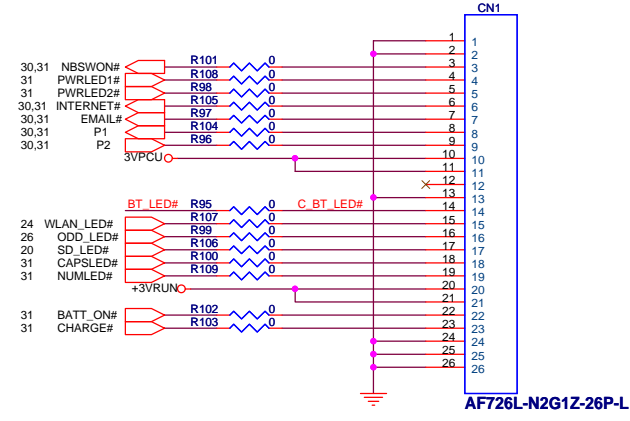
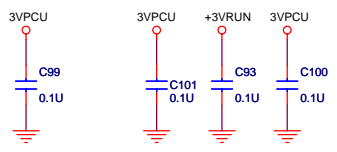

RF SWITCH

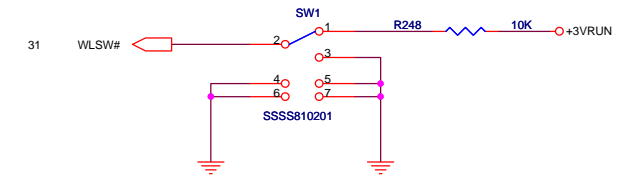

BT CONNECTOR

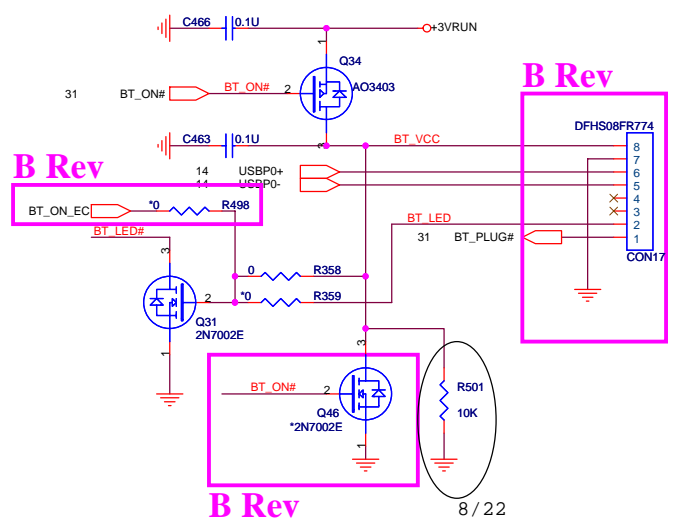

CIR

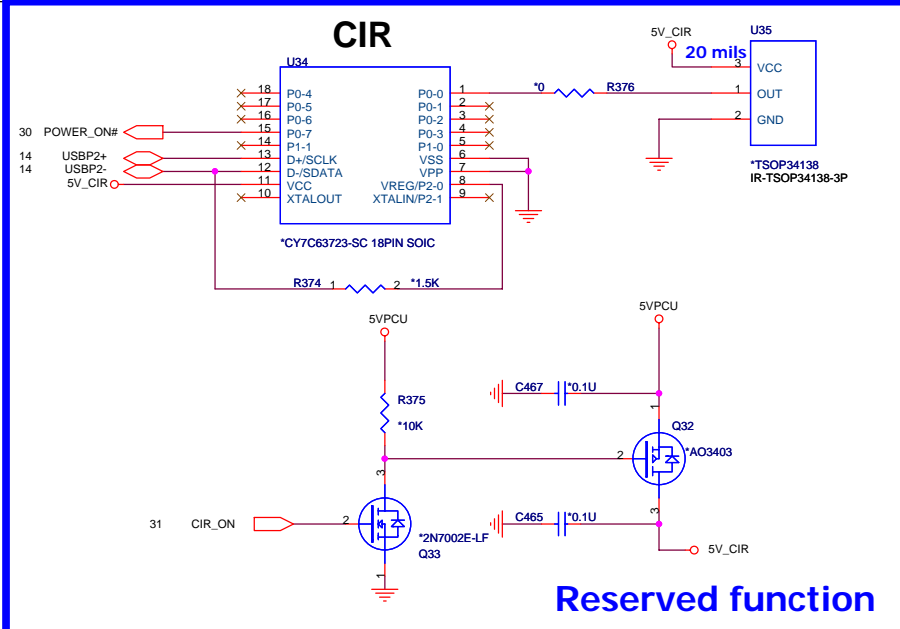

Reserved function

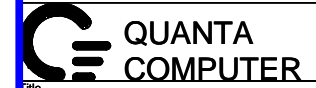

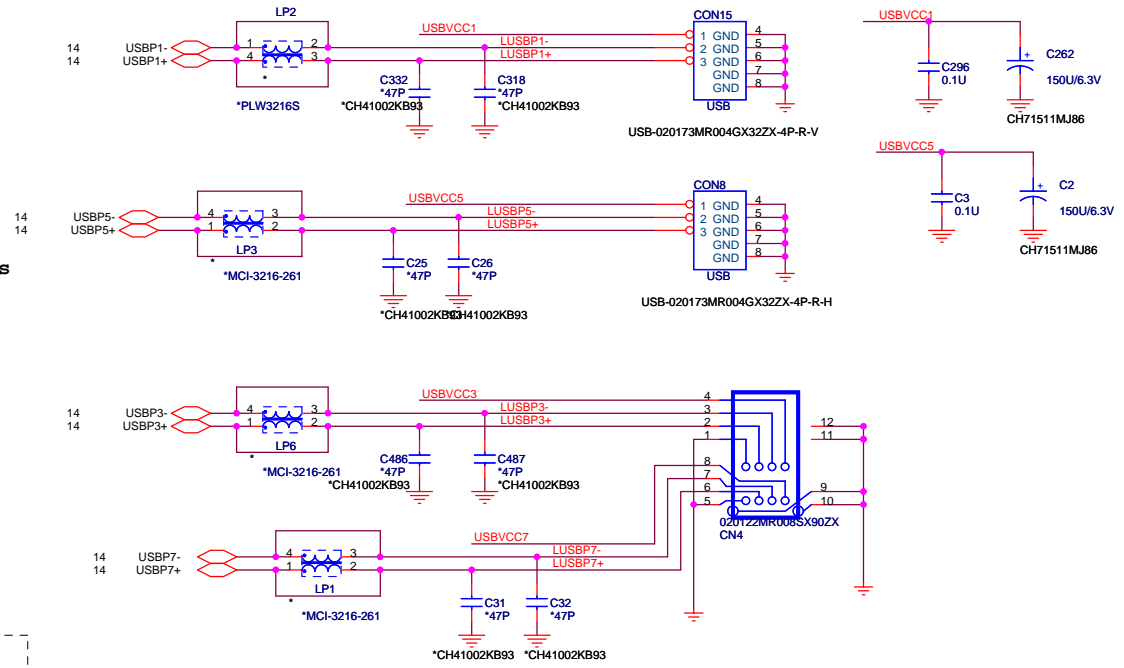
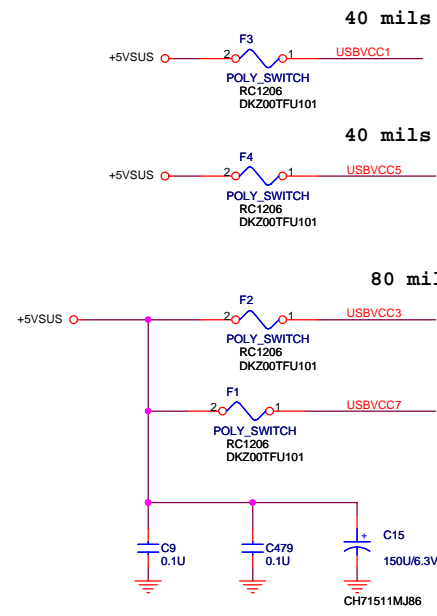

INT K/B

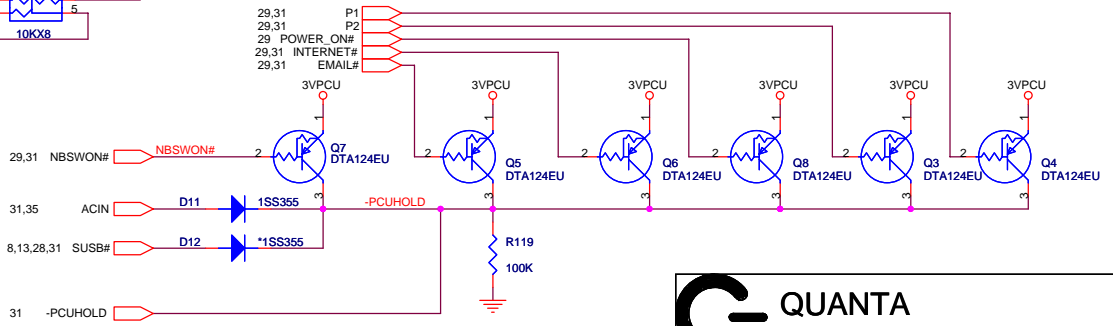
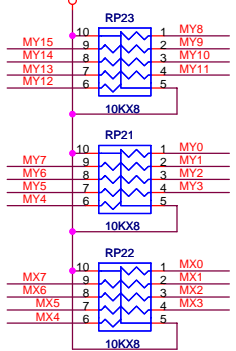
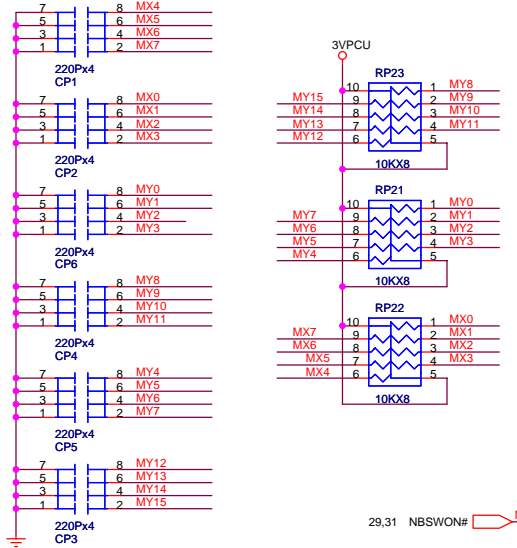
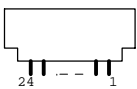
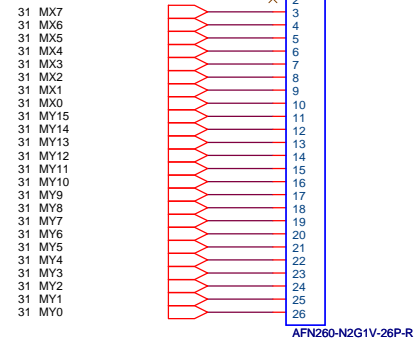

**QUANTA
COMPUTER**

Title: **K/B,USB**

Size	Document Number	Rev
Custom	BQ2L MAIN BOARD	1A

Date: Friday, August 25, 2006 Sheet 30 of 38

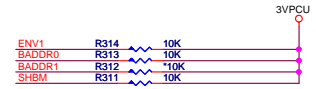
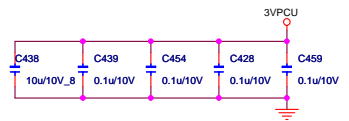

BADDR1-0	Index	Data
0 0	2E	2F
0 1	4E	4F
1 0	(HCFGBAH, HCFGBAL)	(HCFGBAH, HCFGBAL)+1
1 1		Reserved

Should have a 0.1uF capacitor close to every GND-VCC pair + one larger cap on the supply.

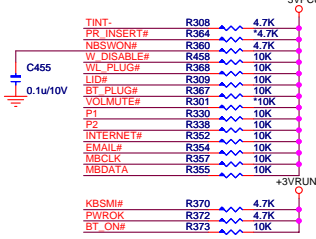

MODEL ID

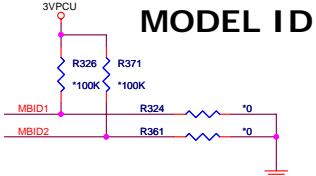

Reserved function

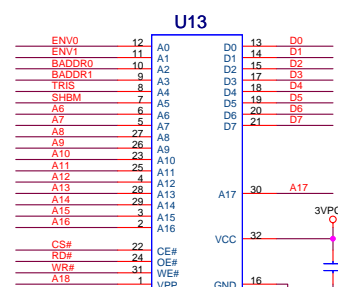

FLASH 8Mbit (1M Byte), NO PLCC TYPE

AMD : Pin 10 is RESET# ; Pin 12 is RY/BY#
SST : Pin 10, 12 are NC

FLASH:
MXI : AKE358AKZ87
SST : AKE352AKK17

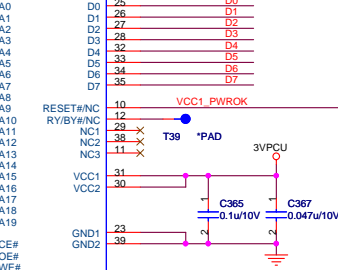

1. AMD-29LV081B require MAX 500ns Tready for it's hardware reset. And MAX6326_UR29 has >100ms reset timing. So we can tie it's reset# pin to +3VALW directly.
2. SIO has internal 20 mS delay of VCC1_PWROK

QUANTA COMPUTER

File: **PC87541V & FLASH**

Size: Custom Document Number: **BQ2L MAIN BOARD** Rev: 1A

Date: Friday, August 25, 2006 Sheet: 31 of 38

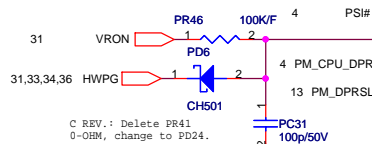
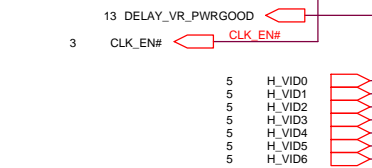
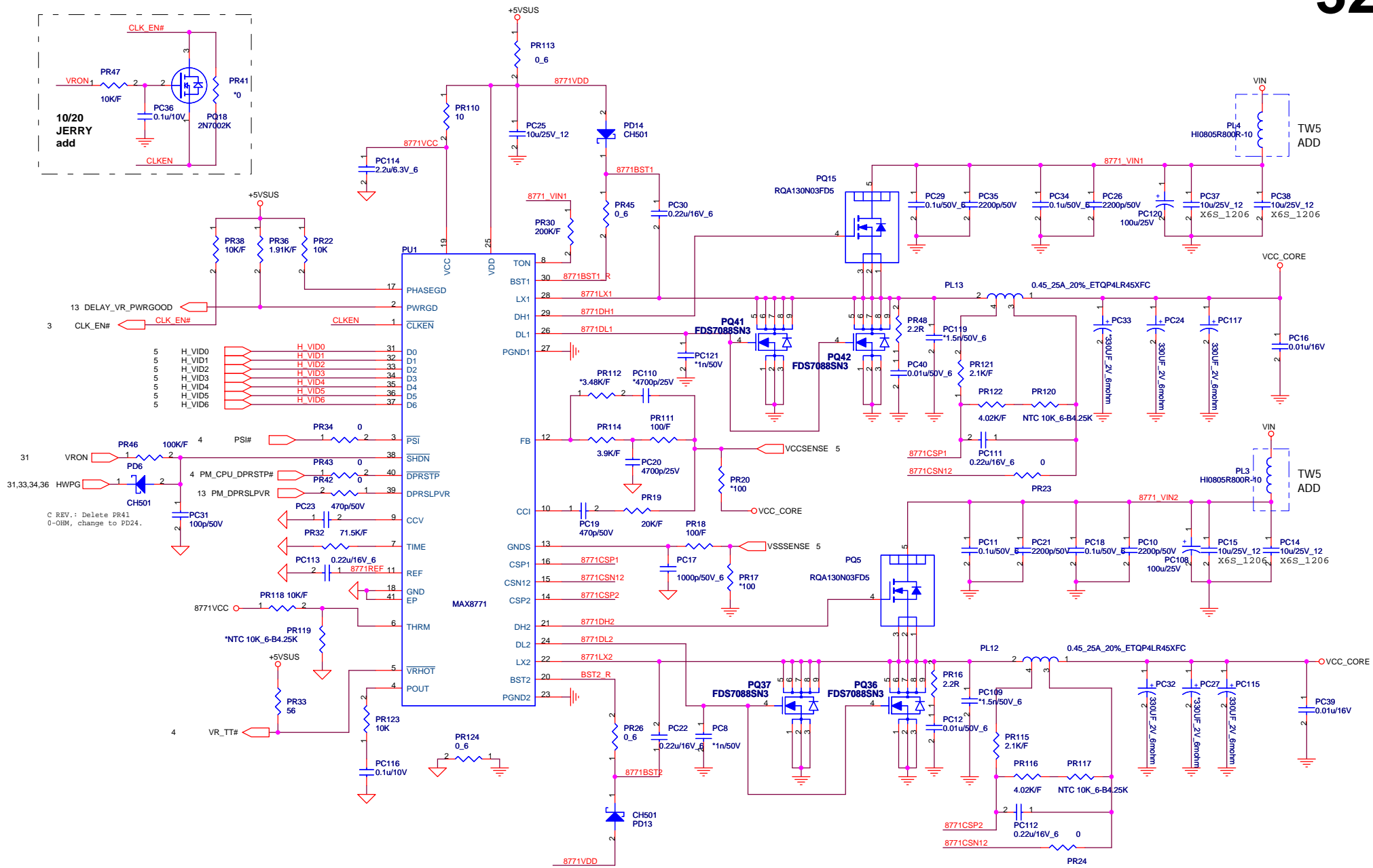
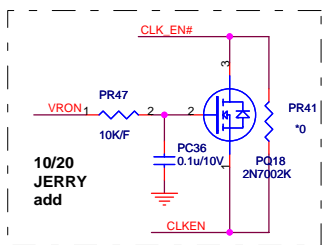

QUANTA COMPUTER		
Title CPU Power MAX8771		
Size Custom	Document Number BQ2L MAIN BOARD	Rev 1A
Date: Friday, August 25, 2006	Sheet 32	of 38

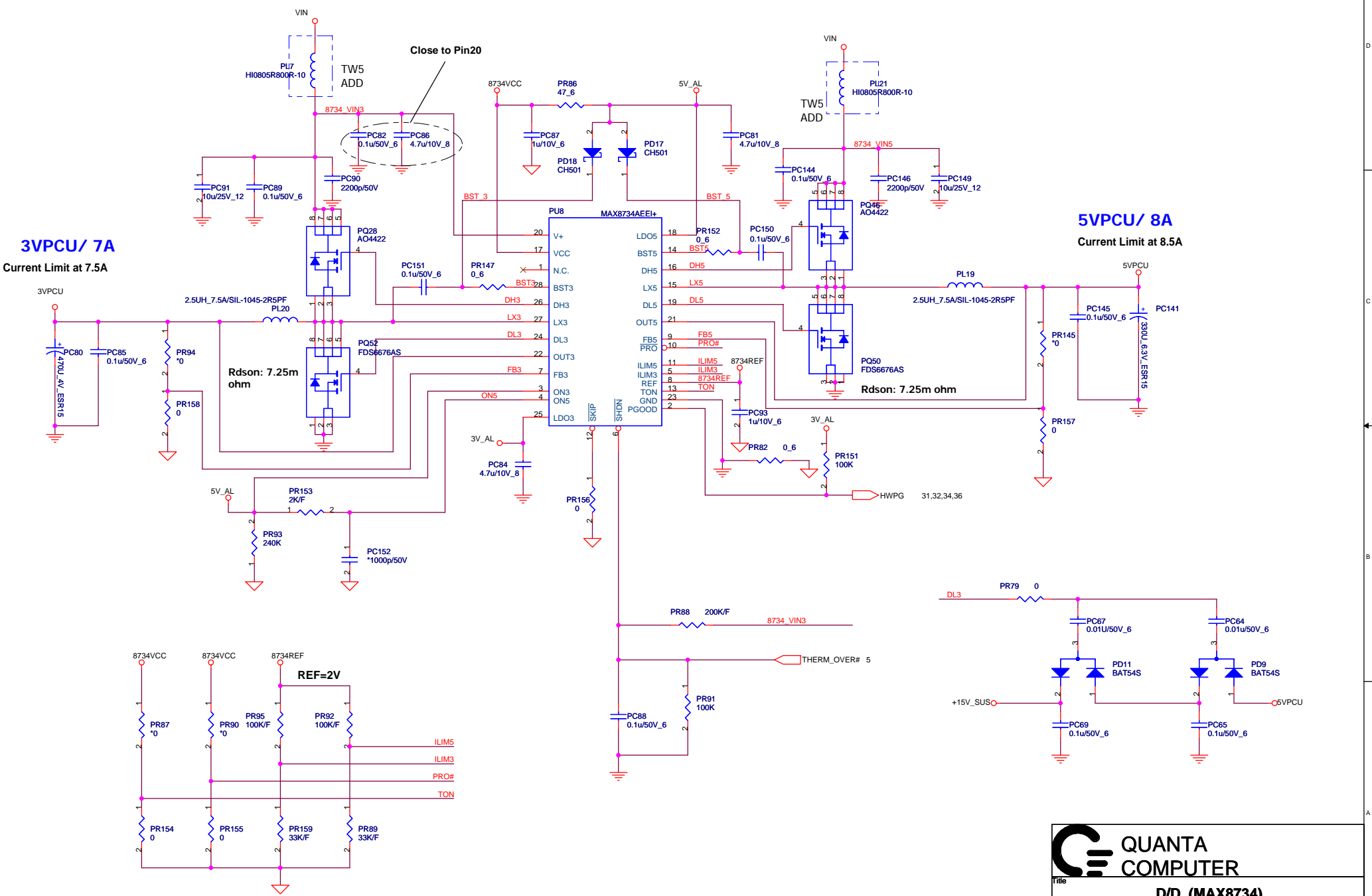

3VPCU/ 7A
Current Limit at 7.5A

5VPCU/ 8A
Current Limit at 8.5A

QUANTA COMPUTER

Title: **D/D (MAX8734)**

Size	Document Number	Rev
Custom	BQ2L MAIN BOARD	1A

Date: Friday, August 25, 2006 Sheet 33 of 38

1.8VSUS/ 6A

Current limit at 8A

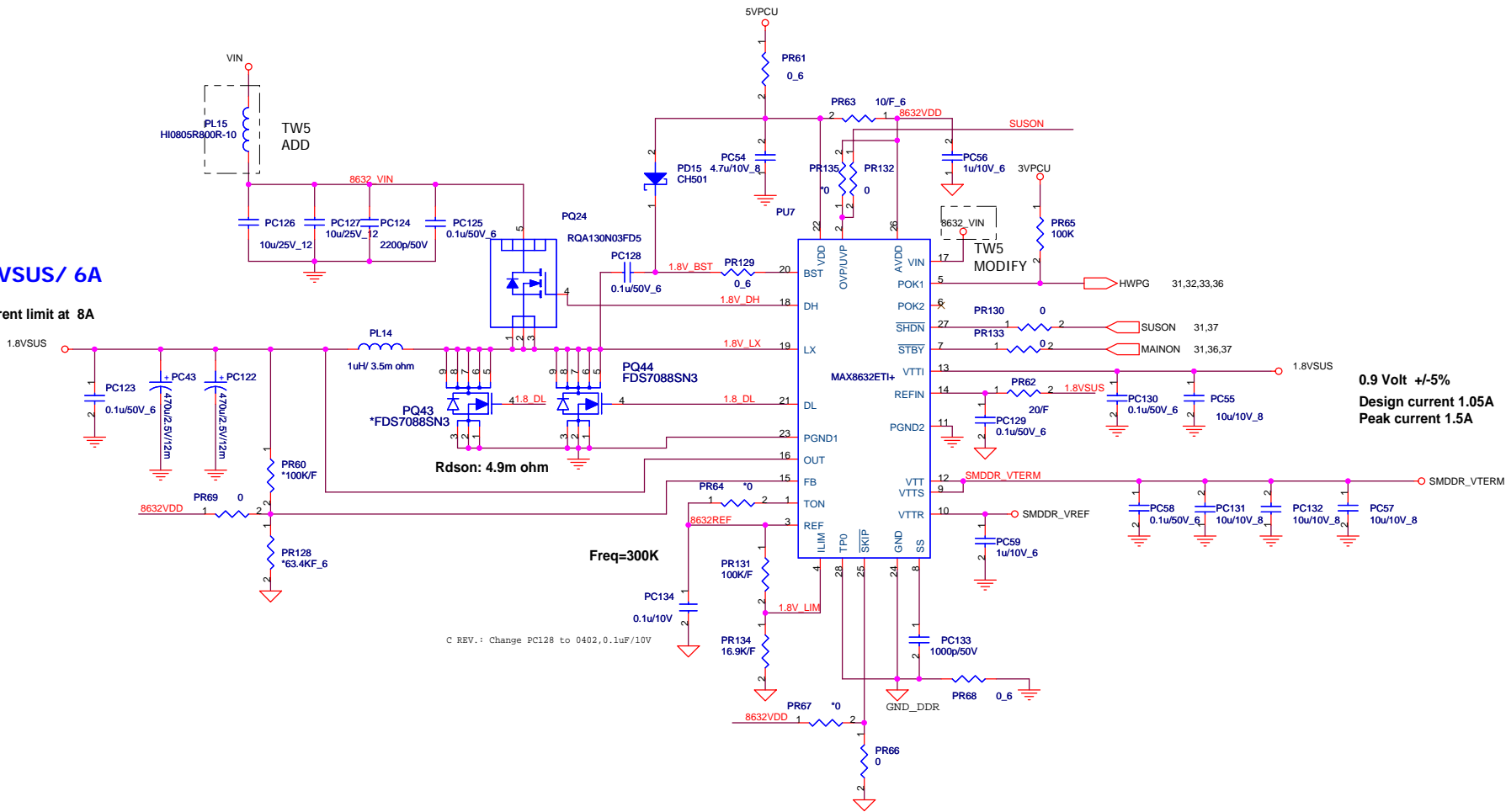

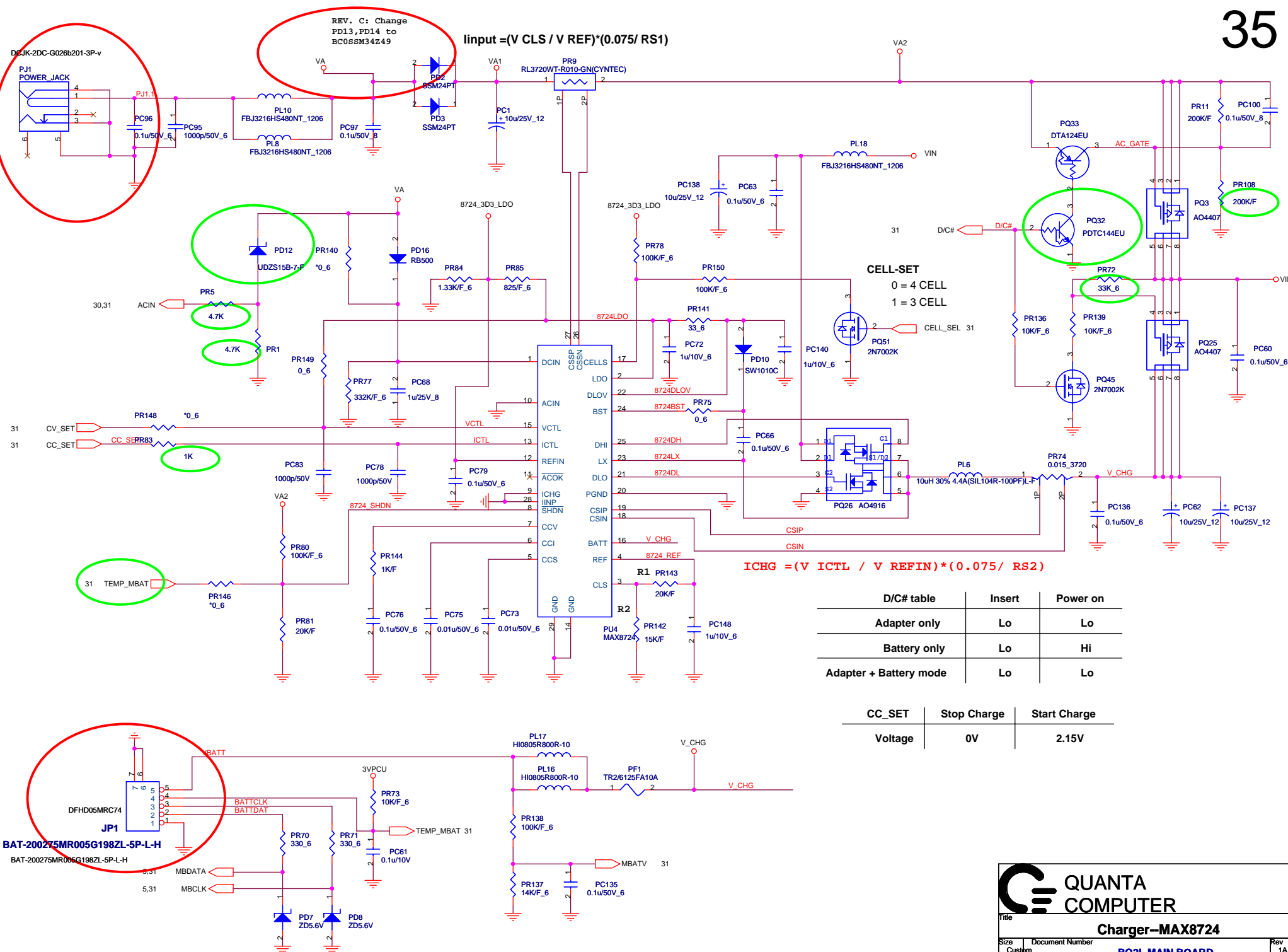

D/C# table	Insert	Power on
Adapter only	Lo	Lo
Battery only	Lo	Hi
Adapter + Battery mode	Lo	Lo

CC_SET	Stop Charge	Start Charge
Voltage	0V	2.15V

QUANTA COMPUTER

Title: **Charger-MAX8724**

Size: Custom Document Number: **BQ2L MAIN BOARD** Rev: 1A

Date: Friday, August 25, 2006 Sheet: 35 of 38

REV. C: Change PQ10 to BAM43920019, PQ11 to BAM48560011 (Thermal Issue)

1.8VRUN/ 6.5A

7.5A Current Limit

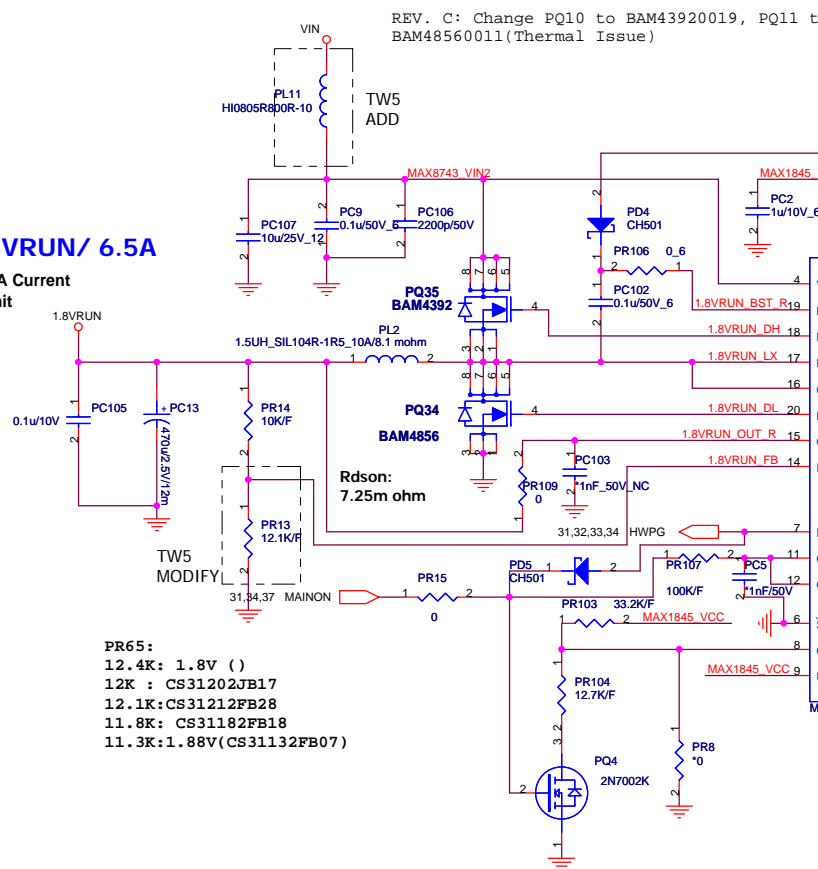

- PR65:
 12.4K: 1.8V ()
 12K : CS31202JB17
 12.1K:CS31212FB28
 11.8K: CS31182FB18
 11.3K:1.88V(CS31132FB07)

+1.05V/ 6A

7A Current Limit

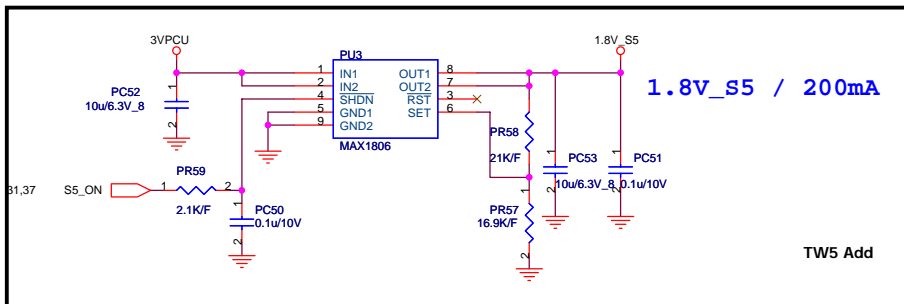
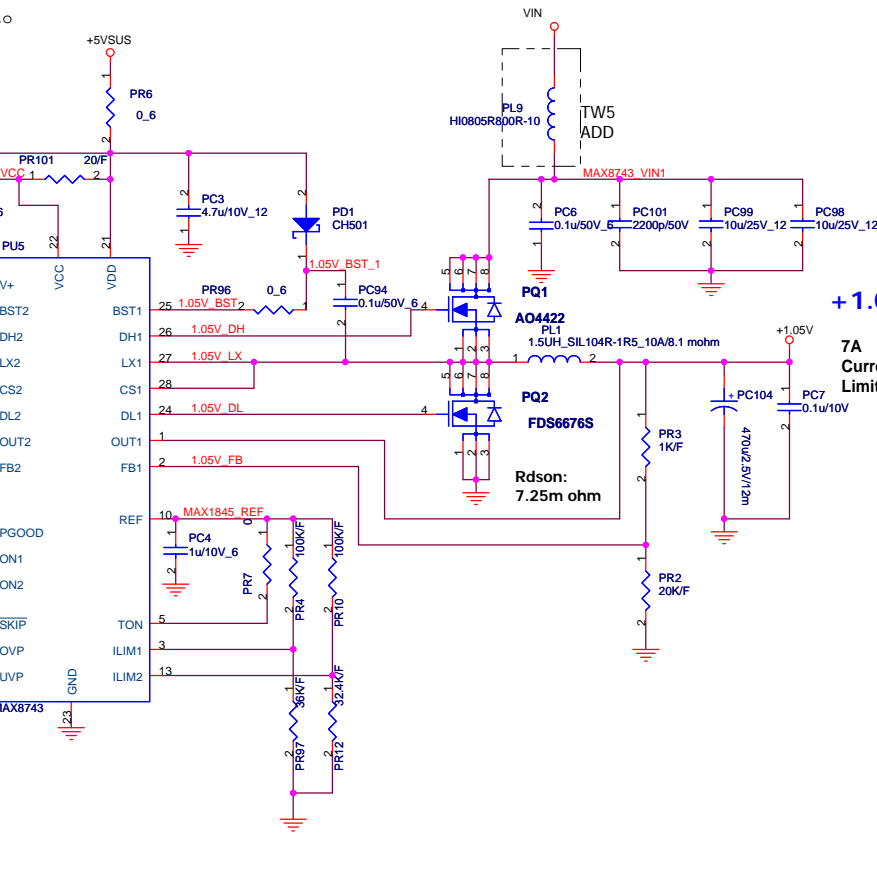

TW5 Add

		QUANTA COMPUTER	
		Title: VCCP(MAX8743)	
Size: Custom	Document Number: BQ2L MAIN BOARD	Rev: 1A	
Date: Friday, August 25, 2006		Sheet: 36	of 38

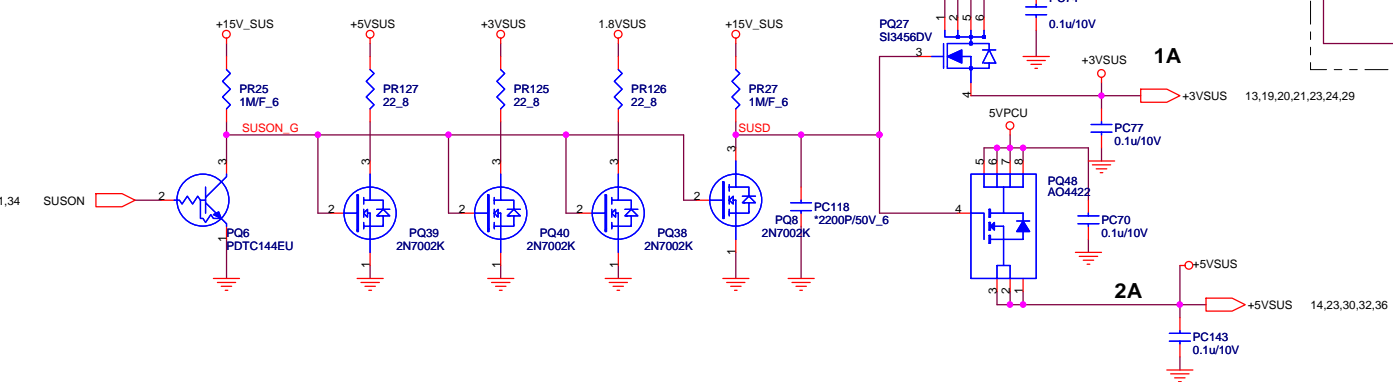
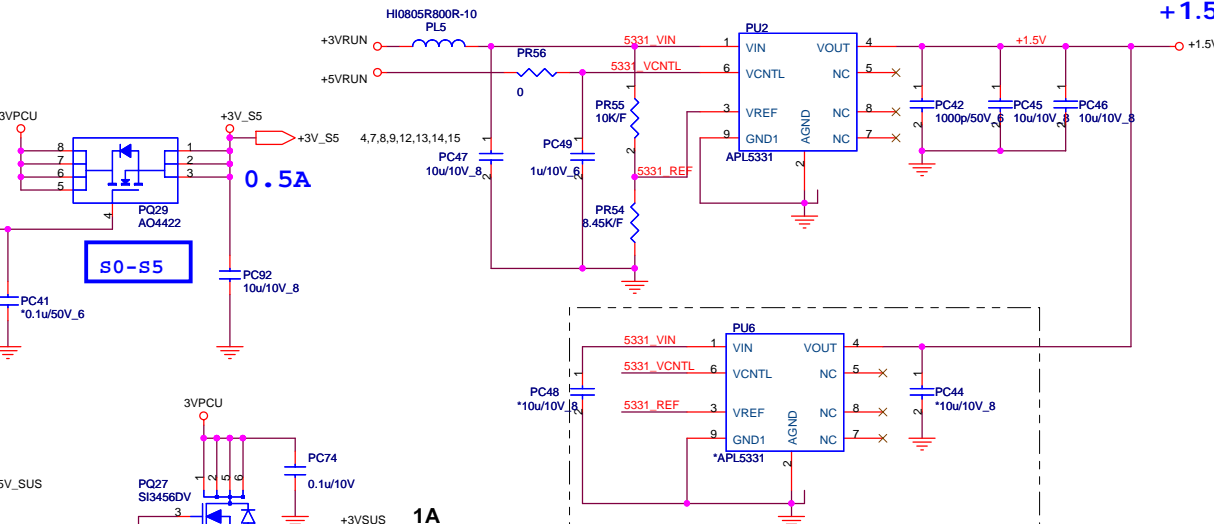
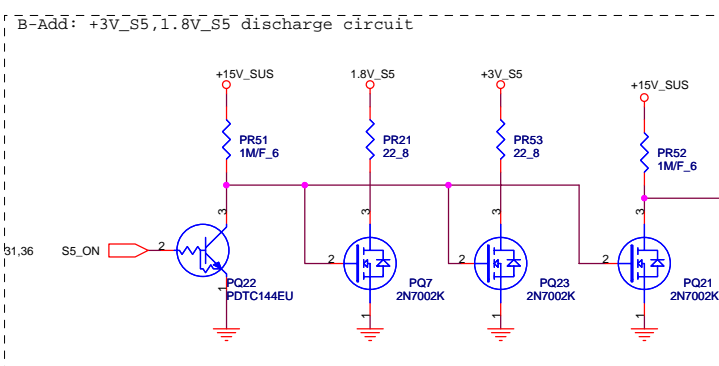
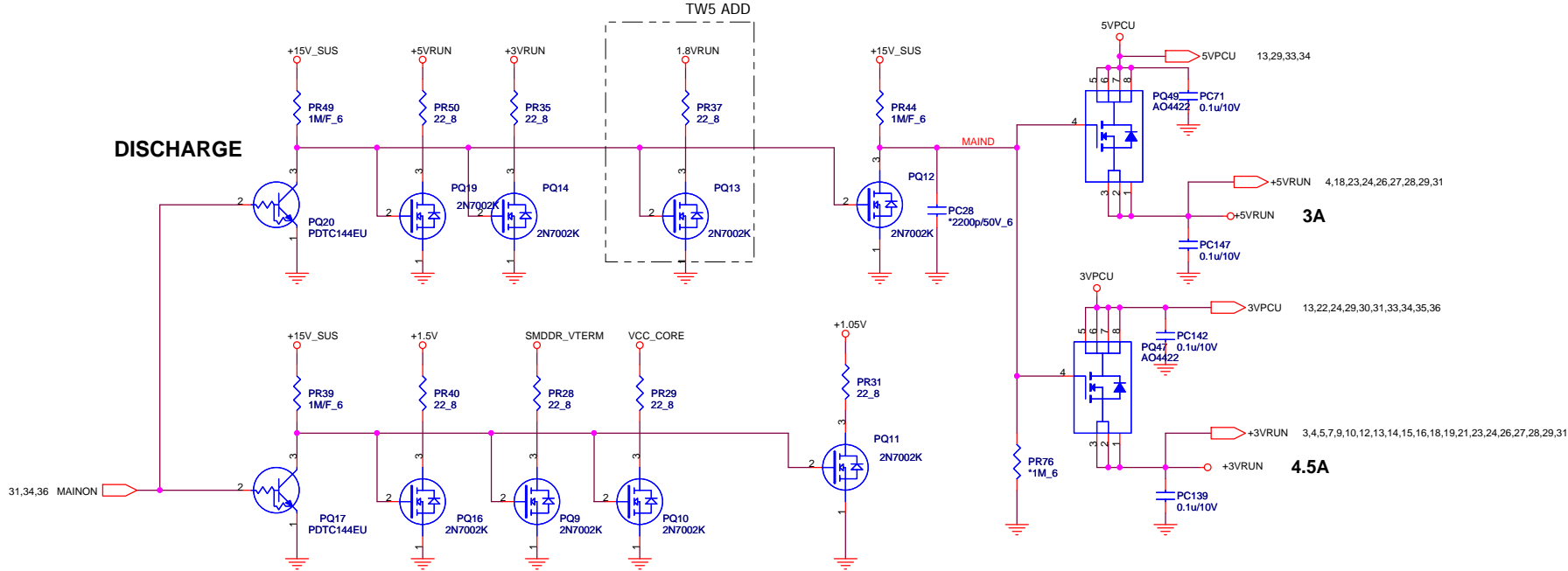

QUANTA COMPUTER

Title: **Discharge Circuit**

Size: Custom	Document Number: BQ2L MAIN BOARD	Rev: 1A
--------------	---	---------

Date: Friday, August 25, 2006 Sheet 37 of 38

B Rev

PAGE-13:SB_HWSPND# change GPIO6 from GPIO0 for reserved function.

PAGE-21:To support newcard hot-plug function.The newcard WAKE# pin must connected to 966L PME# pin.

PAGE-24:Add R454,R455 to support SiS PCIE wireless card.

PAGE-25:Add the connection between GND and LAN_GND

PAGE-26:C385,C387 change 3900PF from 0.01UF

PAGE-28:<1>AU2 change footprint from QFN28-5*5-5 to QFN28-5*5-5-29P

<2>Add SPDIF Power switch design

PAGE-29:<1>B/T interface change PIN definition.

<2>Add Q46 for BT_VCC discharge function.To fix B/T LED abnormal display

<3>Reserved R498 component.EC can control B/T LED.

PAGE-31>Delete PIN175 of signal nets.

 QUANTA COMPUTER			
Title CHANGE HISTORY			
Size Custom	Document Number BQ2L MAIN BOARD	Rev 1A	
Date: Friday, August 25, 2006	Sheet 1	of 38	